

ONKYO® SERVICE MANUAL

COMPACT DISC PLAYER MODEL DX-530



Black model

BUDN, BUD	120V AC, 60 Hz
BUG	220V AC, 50Hz
BUU, BUUX	110/120/220/240V AC, 50/60Hz
BUQA, BUQB	240V AC, 50 Hz

SAFETY-RELATED COMPONENT WARNING!!

COMPONENTS IDENTIFIED BY MARK Δ ON THE SCHEMATIC DIAGRAM AND IN THE PARTS LIST ARE CRITICAL FOR RISK OF FIRE AND ELECTRIC SHOCK. REPLACE THESE COMPONENTS WITH ONKYO PARTS WHOSE PART NUMBERS APPEAR AS SHOWN IN THIS MANUAL.

MAKE LEAKAGE-CURRENT OR RESISTANCE MEASUREMENTS TO DETERMINE THAT EXPOSED PARTS ARE ACCEPTABLY INSULATED FROM THE SUPPLY CIRCUIT BEFORE RETURNING THE APPLIANCE TO THE CUSTOMER.

SPECIFICATIONS

Signal readout system:	Optical non-contact
Reading rotation:	About 500~200 r.p.m. (constant linear velocity)
Linear velocity:	1.2~1.4m/s
Error correction system:	Cross interleave readsolomon code
Decoded bits:	16 bits linear
Sampling frequency:	88.2kHz (two-times oversampling)
Number of channels:	2 (stereo)
Frequency response:	2Hz~20kHz
Total harmonic distortion:	0.003% (at 1kHz)
Dynamic range:	93dB
Signal to noise ratio:	96dB
Channel separation:	90dB (at 1kHz)
Wow and Flutter:	Below threshold of measurability
Power consumption:	17 watts
Output level:	2 volts r.m.s.
Dimensions (W x H x D):	435 x 92 x 364mm 17-1/8" x 3-5/8" x 14-5/16"
Weight:	5.6kg, 12.3 lbs.

Specifications are subject to change without notice.

ONKYO
AUDIO COMPONENTS

TABLE OF CONTENTS

Specifications	1
Service procedures	2
Note on compact disc	3
Protection of eyes from laser beam during servicing	4
Laser Warning label	4
Caution on replacement of pick-up	6
Packing view	7
Exploded view	8
Parts list	9
Mechanism exploded view	10
Parts list	11
Disassembling procedures	12
Ic block diagram & descriptions	14
Flowchart of operation	21
Connection diagram of microcomputer	23
Circuit descriptions	24
Adjustment procedures	28
Printed circuit board view from bottom side	31
Printed circuit board-parts list	33
Block diagram	37

SERVICE PROCEDURES

1. Removing the Locking Plate

Locking plate is located on the bottom panel of this unit. Before using this unit for the first time, the plate must be removed. If power is switched on while this part is still in place, the unit will not operate properly

1. Locking plate
2. Tapping screw

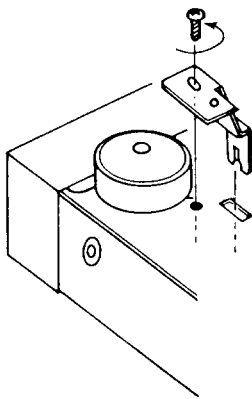

Fig. 1

2. Safety-check out (U.S.A. model)

After correcting the original service problem, perform the following safety check before releasing the set to the customer:

Connect the insulating-resistance tester between the plug of power supply cable and chassis.

Specifications: more than 10Mohm at 500V.

3. Procedures for replacement of flat packaged ICs

1. Tools to be used:

- (1) **Soldering iron** Grounded soldering iron or soldering iron with leak resistance of 10 Mohms or more.

Form of soldering iron's tip:

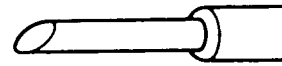

Fig. 2

- (2) **Magnifying glass** . . . for checking of finished works
- (3) **Tweezers** for handling of IC and forming of leads
- (4) **Grounding ring** Countermeasure for electrostatic breakdown
- (5) **Nipper** for removing defective IC
- (6) **Small brush** for application of flux

2. Work Procedures:

(1) Remove the defective IC

Cut all leads of the defective IC one by one using a nipper and remove the IC.

(2) Clean the pattern surface of the PC board.

Get rid of the remaining leads and solder.

(3) Check and from the leads of the new flat packaged IC to be installed.

From every lead on the new IC using a pair of tweezers, so that all of them are aligned neatly without being risen, twisted or inclined toward one side. Especially the rising portion of every lead must be formed with greatest care.

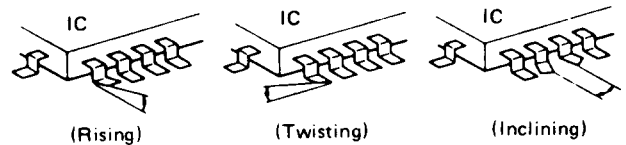
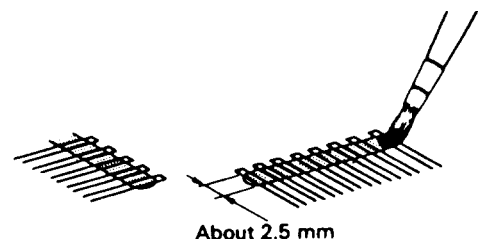

Fig. 3

(4) Apply flux to the PC board.

Apply flux to the pattern surface of the PC board which has been cleaned, as shown in the illustration. The area to be applied with flux is the portion of about 2.5mm in width where the IC's leads are to be soldered.

Be careful to apply minimum amount of flux required so as not to smear it on unwanted areas.



About 2.5 mm

Fig. 4

(5) Temporarily tighten the IC

Carefully align the pattern and IC's leads, so that the IC will be temporarily tightened to the pattern on the four leads at the corners. At this time, soldering is required, but no need to apply soldering material.

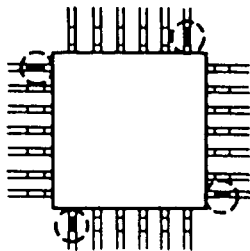

Fig. 5

(6) Apply flux to IC's leads

Apply flux to the areas of IC's leads where soldering is to be performed. Be careful not to smear flux on the root portion of any lead or the body of IC.

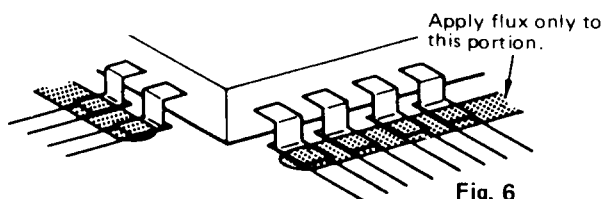

Fig. 6

(7) Soldering

While attaching the tip of the soldering iron to the soldering point as shown in the illustration, feed 2–5mm of soldering wire. Then, slowly move the iron in the direction indicated by the arrow in the illustration, so that the leads will be soldered to the pattern. Move the iron in the rate of approximately 1cm in 5sec. Proceed with your work while confirming a clean fillet of solder is formed on each lead, subsequent to the melting of flux.

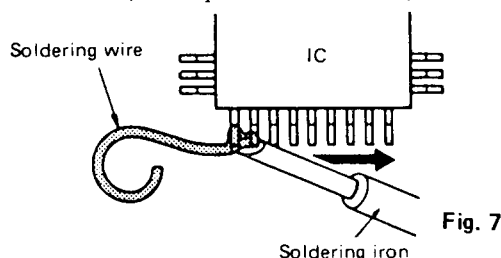

Fig. 7

CAUTION

- 1) If you move the iron too quickly, loose soldering is likely to result.
 - 2) Be especially careful when soldering the first lead where loose soldering is most liable to be formed.
- (8) Check the results**

When soldering of all leads is finished, check the soldered portion on every lead with a magnifying glass. A tester must not be used or checking of any soldered position

NOTE ON COMPACT DISC**• Holding Compact Discs**

Hold Compact Discs by the edges so that you do not touch

the surface of disc. Remember that the side of the disc with the "rainbow" reflection is the side containing the audio information.

Do not attach tape or paper to the label side of the disc and always be careful not to leave fingerprints on the side that is played.

• Storing Compact Discs

Store Compact Discs in a location protected from direct sunlight, high heat and humidity and extremely high and low temperatures. Discs should never be left in the trunk or interior of an automobile in the sun since the temperature can become very high in such a closed environment.

Always store Compact Discs in the holders in which they were sold. Never leave a disc in the player's disc holder for a long period of time.

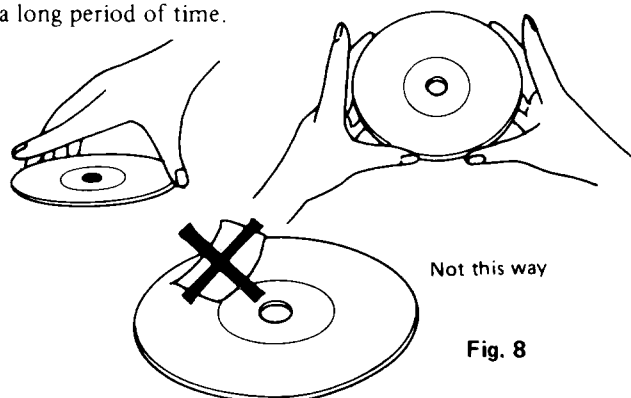

Fig. 8

• Cleaning Compact Discs

Before playing a disc wipe off the playing surface with a soft cloth to remove dust and other soil. Wipe the surface in straight lines from the center of the disc outward, not in a circular motion as you would with a phonograph record.

Do not use benzene, chemical cleansers or phonograph record cleaning solutions to clean Compact Discs. Also avoid static electricity prevention solutions since they can damage the surface of Compact Discs.

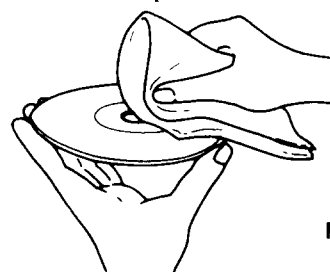

Fig. 9

Problems Caused by Dew

Dew can form inside a Compact player when it is brought from a cold environment into a warm room, when a room is rapidly heated and if a player is left in a humid environment.

This dew can prevent the laser pickup from reading the data contained in the pits in the disc surface. If the player does not operate properly because of dew, remove the disc and leave the player's power switch on for about one hour to remove all moisture.

PROTECTION OF EYES FROM LASER BEAM DURING SERVICING

This set employs a laser. Therefore, be sure to follow carefully the instructions below when servicing.

WARNING!!

WHEN SERVICING, DO NOT APPROACH THE LASER EXIT WITH THE EYE TOO CLOSELY. IN CASE IT IS NECESSARY TO CONFIRM LASER BEAM EMISSION, BE SURE TO OBSERVE FROM A DISTANCE OF MORE THAN 30cm FROM THE SURFACE OF THE OBJECTIVE LENS ON THE OPTICAL PICK-UP BLOCK.

LASER WARNING LABEL

The label shown below are affixed.

1. Warning label

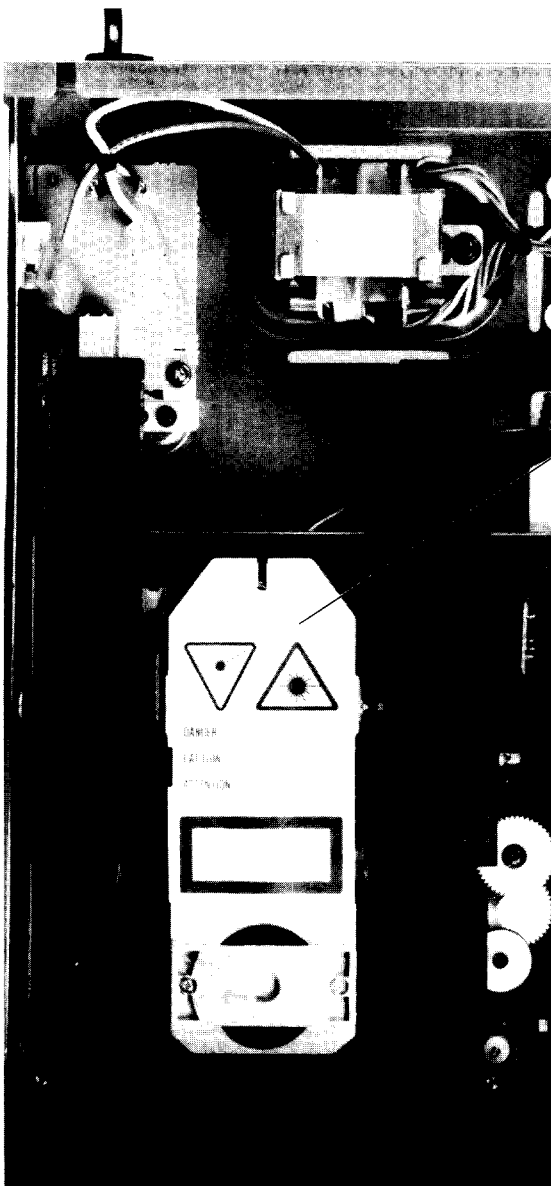

Laser Diode Properties

- Material: GaAS/GaAlAs
- Wavelength: 780nm
- Emission Duration: continuous
- Laser output: max. 0.5mW*

*This output is the value measured at a distance about 1.8mm from the objective lens surface on the Optical Pick-up Block.

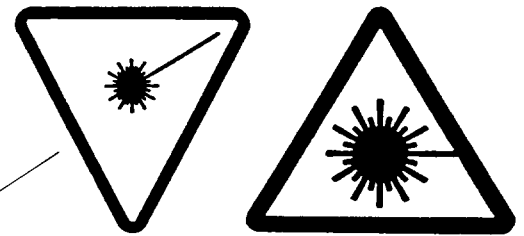

DANGER —INVISIBLE LASER RADIATION WHEN OPEN AND INTERLOCK FAILED OR DEFEATED. AVOID DIRECT EXPOSURE TO BEAM.

CAUTION —HAZARDOUS LASER AND ELECTROMAGNETIC RADIATION WHEN OPEN AND INTERLOCK DEFEATED.

ATTENTION —RAYONNEMENT LASER ET ELECTROMAGNETIQUE DANGEREUX SI OUVERT AVEC L'ECLANCHEMENT DE SECURITE ANNULE.

SN29360911

ADVARSEL: USYNLIG LASERSTRÅLING VED ÅBNING, NÅR SIKKERHEDSAFBRYDER ER UDE AF FUNKTION. UNDGÅ UDSÆTTELSE FOR STRÅLING.

Photo 1

2. Certification label (UD: 120V model)

This label is located on the back panel.

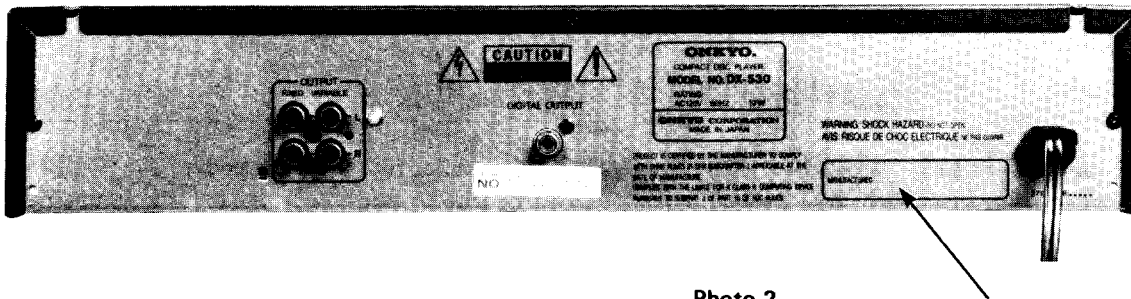

Photo 2

3. Class 1 label (Other models)

This label is located on the back panel.

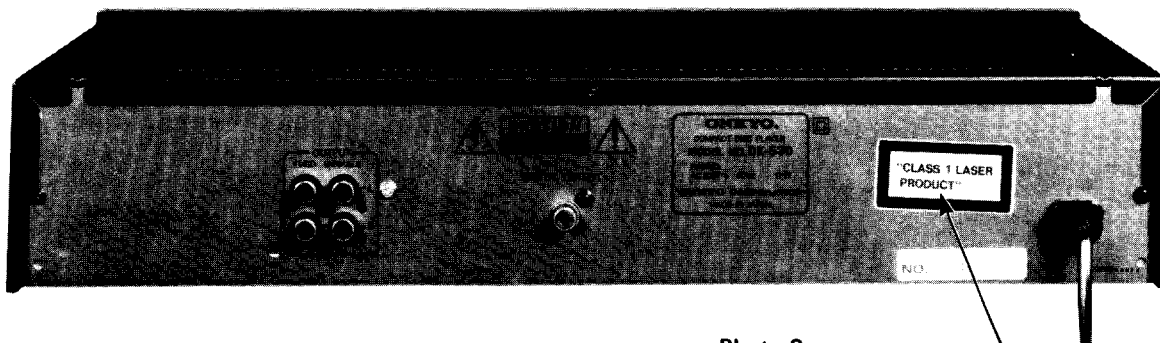

Photo 3

ADVARSEL

"CLASS 1 LASER
PRODUCT"

Denne mærkning er anbragt på apparatets højre side og indikerer, at apparatet arbejder med laserstråler af klasse 1, hvilket betyder, at der anvendes laserstråler af svageste klasse, og at man ikke på apparatets yderside kan blive udsat for utilladelig kraftig stråling.

APPARATET BØR KUN ÅBNES AF FAGFOLK MED SÆRLIGT KENDSKAB TIL APPARATER MED LASERSTRÅLER!

Indvendigt i apparatet er anbragt den her gengivne advarselmærkning, som advarer imod at foretage sådanne indgreb i apparatet, at man kan komme til at udsætte sig for laserstråling.

ADVARSEL USYNLIG LASERSTRÅLING
VED ÅBNING, NÅR SIKKERHEDSAF
BRYDER ER UDE AF FUNKTION
UNDGÅ UDSÆTTELSE FOR STRÅLING

VAROITUS! Laitte sisältää laserdiodin, joka lähettää (näkymätöntä) silmille vaarallista lasersäteilyä.

Fig. 10

CAUTION ON REPLACEMENT OF PICK-UP

The laser diode in the optical pick-up block is so sensitive to static electricity, surge current and etc. that the components are liable to be broken down or its reliability remarkably deteriorated.

During repair, carefully take the following precautions. (The following precautions are included in the service parts).

PRECAUTIONS

1. Ground for the work-desk.

Place a conductive sheet such as a sheet of copper (with impedance lower than $10^6 \Omega$) on the work-desk and place the set on the conductive sheet so that the chassis.

2. Grounding for the test equipment and tools.

Test equipments and toolings should be grounded in order that their ground level is the same the ground of the power source.

3. Grounding for the human body.

Be sure to put on a wrist-strap for grounding whose other end is grounded.

Be particularly careful when the workers wear synthetic fiber clothes, or air is dry.

4. Select a soldering iron that permits no leakage and have the tip of the iron well-grounded.

5. Do not check the laser diode terminals with the probe of a circuit tester or oscilloscope.

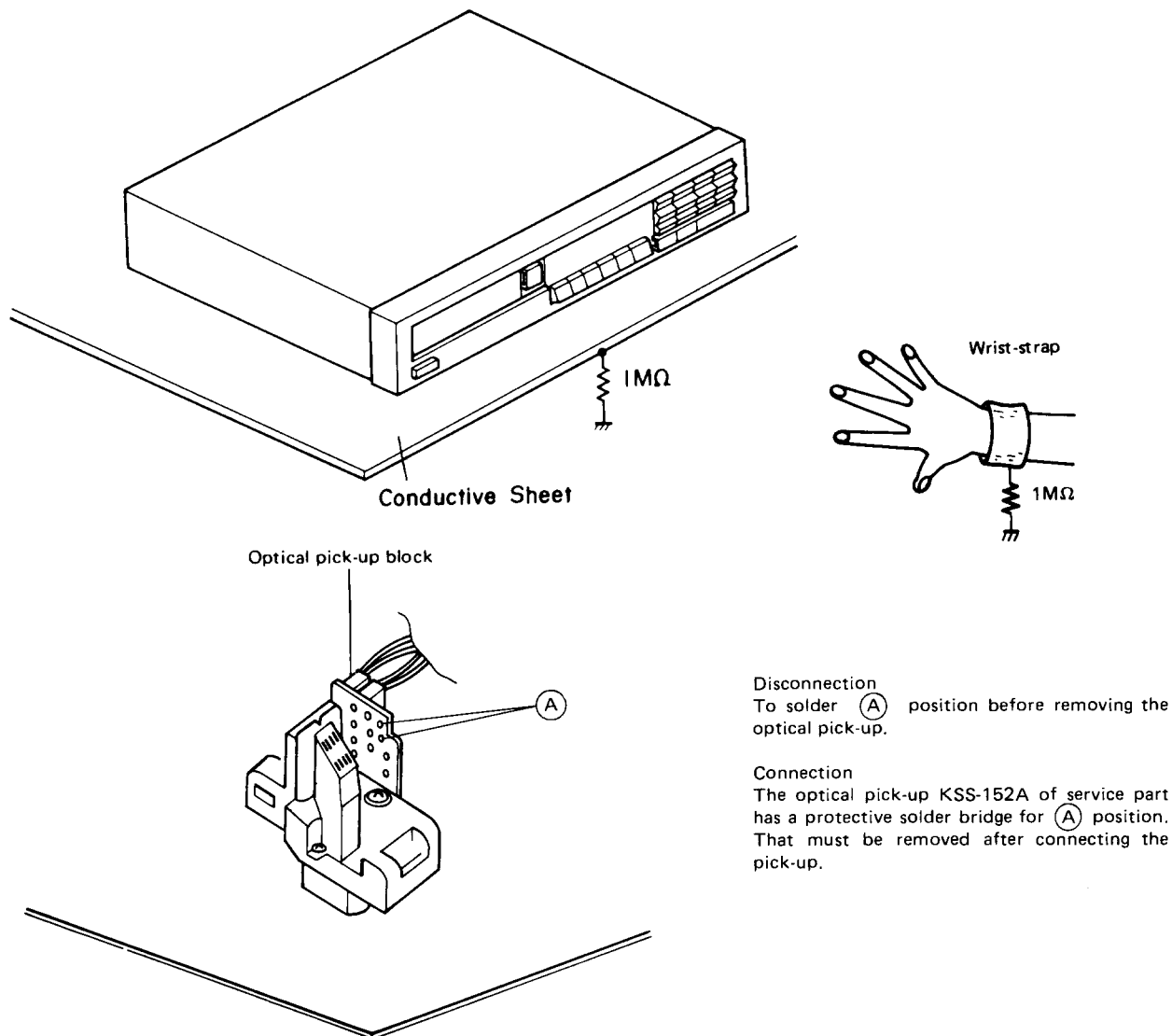

Fig. 11

Disconnection

To solder (A) position before removing the optical pick-up.

Connection

The optical pick-up KSS-152A of service part has a protective solder bridge for (A) position. That must be removed after connecting the pick-up.

PACKING VIEW

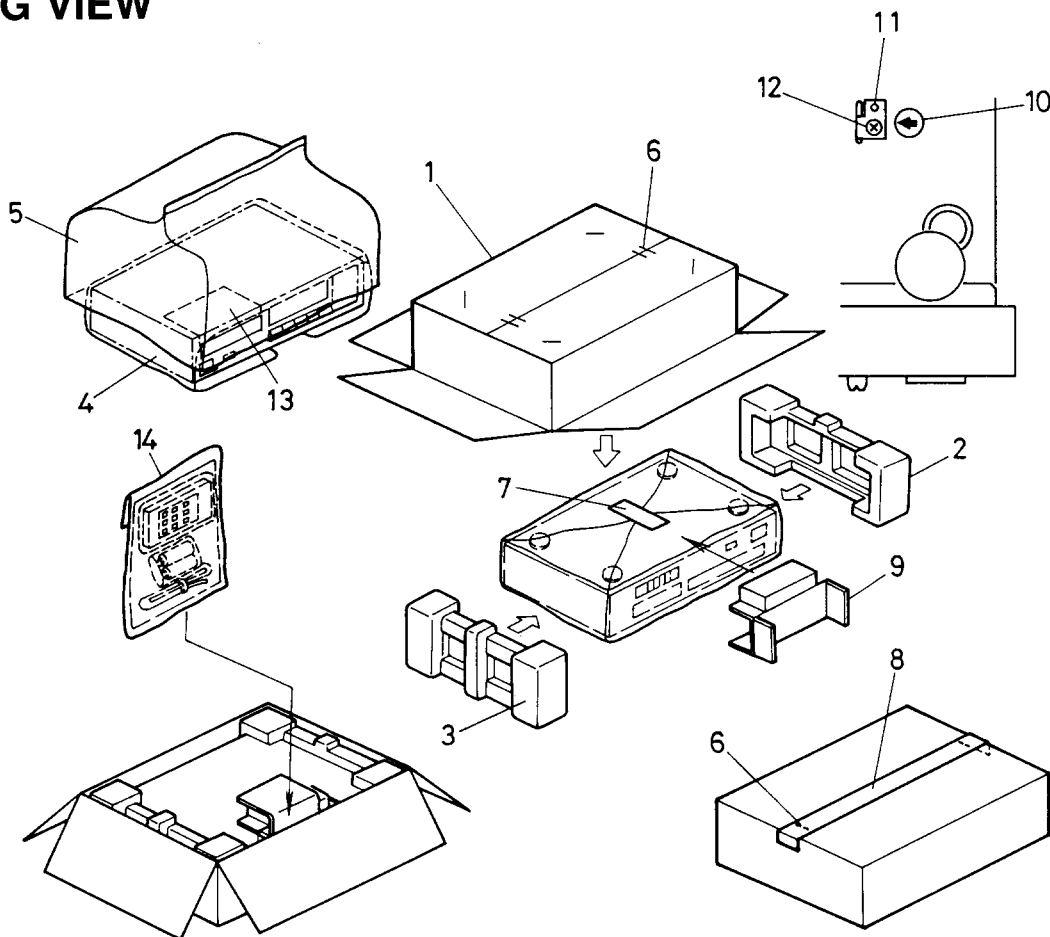

REF. NO.	PART NO.	DESCRIPTION
1	29051508	Master carton box
2	29091110A	Pad L
3	29091111A	Pad R
4	29095012-1	800X500mm, Protection sheet
5	29100036A	550X850mm, Poly-vinyl bag
6	282301	Sealing hook
7	261504	Adhesive tape
8	260012	Damplon tape
9	29091170	Pad F
10	29360833	Label
11	27141103A	Locking plate
12	834430068	3TTS+6B(BC), Tapping screw
13	29360907	Label, locking plate
14	Accessory bag ass'y	
	-120V model-	
	29341139	Instruction manual
	2010097	Connection cord
	24140004	RC-106C, Remote control unit
	3010054	UM-3, Two batteries
	29100097	250X350mm, Poly-vinyl bag
	29365019	Warranty card (Only U.S.A. model)
	29358002E	Service station list (Only U.S.A. model)
	-220V/240V/Universal models-	
	29341140	Instruction manual
	29341170	Instruction manual, Italian (Only 220V model)
	2010097	Connection cord
	24140004	RC-106C, Remote control unit
	3010054	UM-3, Two batteries
	29100097	250X350mm, Poly-vinyl bag
	25055040	CV-K-2, Conversion plug (Only Universal model)

EXPLODED VIEW

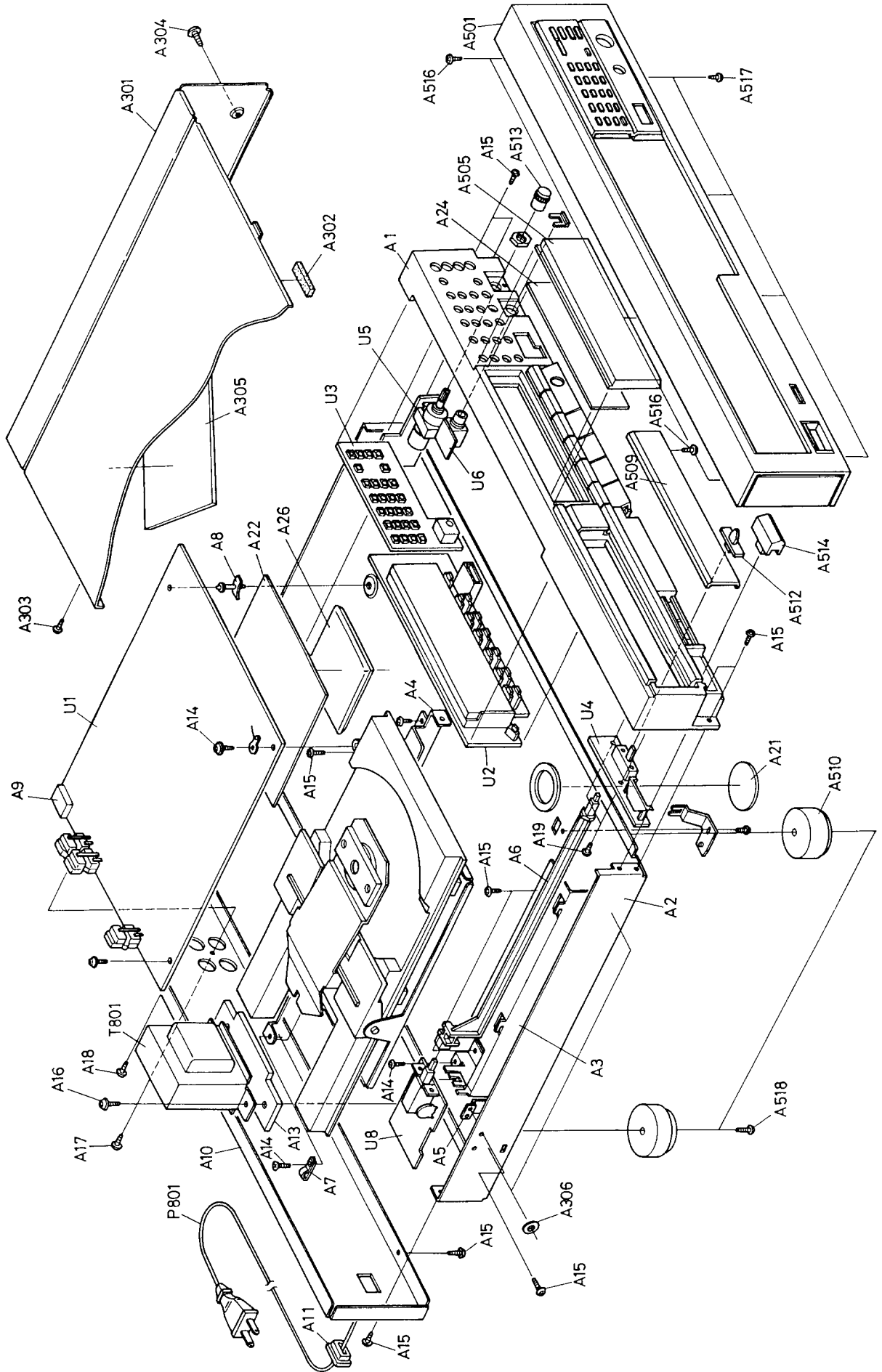

EXPLODED VIEW – PARTS LIST

REF.NO.	PART NO.	DESCRIPTION	REF.NO.	PART NO.	DESCRIPTION
A1	27110355	Front bracket	T801	2300223	NPT-952Q, Power transformer <Q>
A2	27100131A	Chassis	S902	25065168	HXW0131-01-060, Voltage selector switch <U>
A3	27130466	Bracket L	P801	253112A	AS-UC-4 #18, Power supply cord <D/PX>
A4	27130467	Bracket R		253127B or	AS-CEE, Power supply cord <G/U>
A5	27141125	Bracket S		253129A	
A6	27273057A	Joint	U1	1H016529-2	AS-SAA, Power supply cord <Q>
A7	27255001	Clamper for lead wire	U2	1H016530-2	NAAR-2929-2, Main circuit pc board ass'y
A8	27190009	Holder		1H016531-2	NADIS-2930-2, Display pc board ass'y
A9	28140773	Cushion	U3	1H016532-2	NASW-2931-2, Operation switch pc board ass'y
A10	27120978	Back panel <D>	U4	1H016532-2	NASW-2932-2, Timer switch pc board ass'y
	27120979	Back panel <G>	U5	1H016533-2	NAAF-2933-2, Output volume pc board ass'y
	27120981	Back panel <U>	U6	1H016534-2	NAAF-2934-2, Headphone terminal pc board ass'y
	27121021	Back panel <Q>	U8	1H016536-2	NAPS-2936-2, Power switch pc board ass'y
	27300750	Strainrelief		29360911	Label, laser
A11	27270214	Spacer		29360687	Label, Class 1 <G/U/Q>
A13	831130088	3TTW+8B, Tapping screw			
A14	834430068	3TTS+6B(BC), Tapping screw			
A15	830440109	4TTC+10C(BC), Tapping screw			
A16	834430108	3TTS+10B(BC), Tapping screw			
A17	834230108	3TTS+10B(Ni), Nickel screw			
A18	833430080	3TTP+8P(BC), Tapping screw			
A19	27270193	Spacer			
A21	28140753A	Cushion			
A22	28133180	Back plate			
A24	28140754-1	Cushion ass'y			
A26	28184339	Top cover			
A301	28140020	Cushion			
A302	834430068	3TTS+6B(BC), Tapping screw			
A303	838440089	4TTB+8C(BC), Tapping screw			
A304	28140740	Cushion			
A305	27270212	Spacer			
A306	1H015121	Front panel ass'y			
A501	28191392	Clear plate			
A505	27210847	Door			
A509	27175152	Leg			
A510	28322913	Timer knob			
A514	28323031	Tone knob			
A515	28323040	Power knob			
A516	833430080	3TTP+8P(BC), Tapping screw			
A519	838430088	3TTS+8B(BC), Tapping screw			
A520	831430088	3TTW+8B(BC), Tapping screw			
A521	2000627D	NSAS-8P-583, Socket			
SC801	2000581D	NSAS-8P-537, Socket			
SC802	2300221	NPT-952D, Power transformer <D>			
T801	2300222	NPT-952G, Power transformer <G>			
	2300224	NPT-952ADGQ, Power transformer <U>			

NOTE: <D>: Only 120V model
 <G>: Only 220V model
 <Q>: Only 240V model
 <U>: Only Universal model
 <PX>: Only PX model

NOTE: THE COMPONENTS IDENTIFIED BY MARK **▲** ARE CRITICAL FOR RISK OF FIRE AND ELECTRIC SHOCK. REPLACE ONLY WITH PART NUMBER SPECIFIED.

MECHANISM EXPLODED VIEW

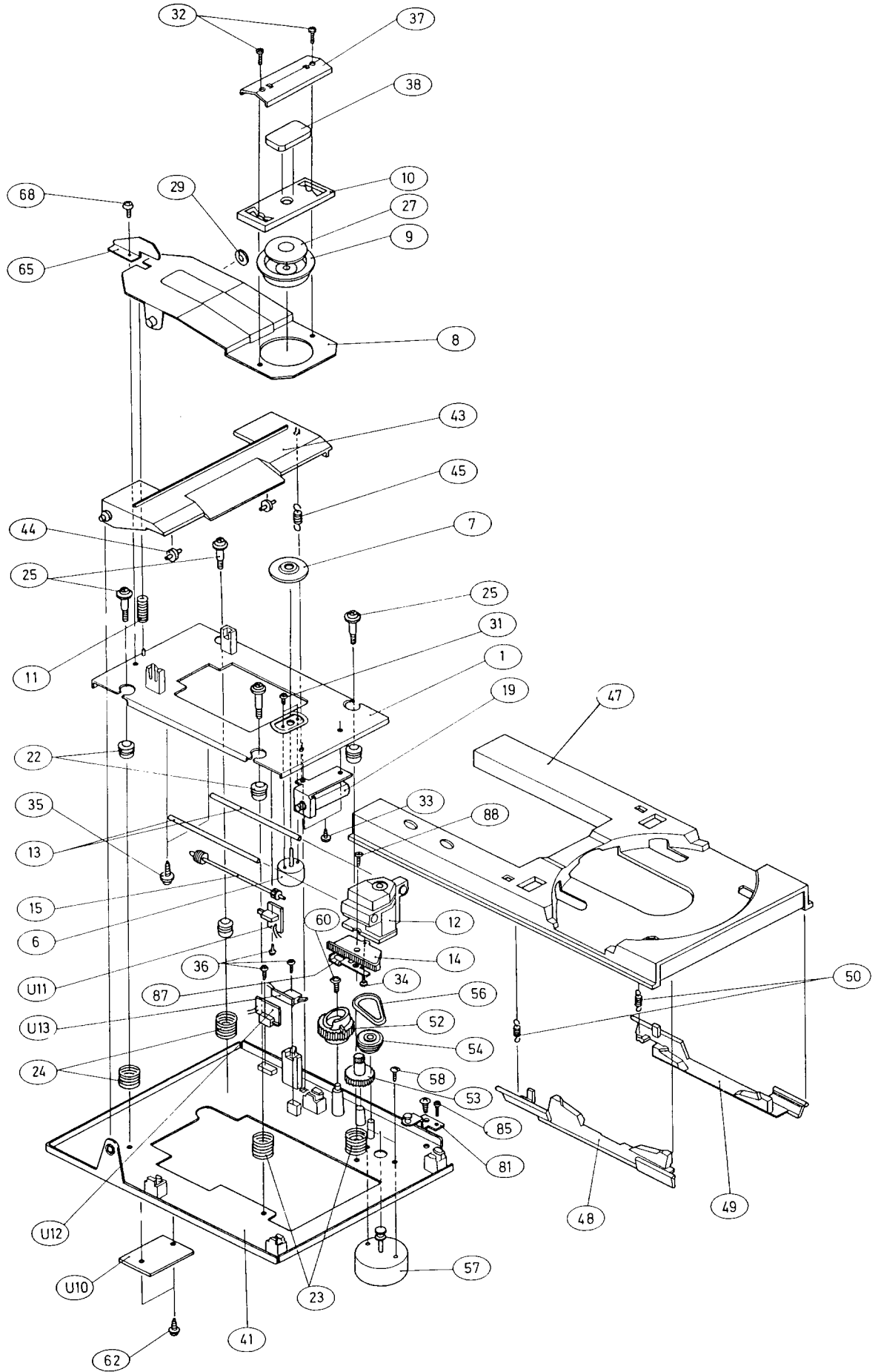

PARTS LIST

REF.NO.	PART NO.	DESCRIPTION
1	27100123A	Chassis (PU)
6	24502213	Spindle motor
7	27300889B	Turntable platter
8	27300932	Arm P
9	27300848A	Cap CH
10	27300849C	Cap holder
11	27180327	Spring
12	24110001	KSS-152A, Optical pickup
13	27260222	Shaft
14	27300897B	Rack PU
15	10498902	Shaft ass'y
19	10498903-1	Motor ass'y
22	27300854A	Cushion rubber
23	27180319	Spring
24	27180320	Spring
25	801364	Special screw
27	27270206	Spacer
29	27270203	Spacer
31	82142003	2P+3F(BC), Pan head screw
32	82112610	2.6P+10F, Pan head screw
33	834426068	2.6TTS+6B(BC), Tapping screw
34	833420068	2TTP+6B(BC), Tapping screw
35	831430100	3TTW+10P(BC), Tapping screw
36	833420108	2TTP+10B(BC), Tapping screw
37	27141138A	Bracket CAP
38	27300931	Rubber CAP
41	27100124B	Chassis
43	27300938	Arm L
44	27185019A	Roller
45	27180310B	Spring
47	27300861D	Disc tray
48	27300900	Disc lifter L
49	27300901A	Disc lifter R
50	27180311C	Spring
52	27300856B	Cam gear
53	27300857B	Flat wheel
54	27300858	Pulley gear
56	27300860	Rubber belt
57	10498901	BF77B, Motor ass'y
58	82142604	2.6P+4F(BC), Pan head screw
60	831430100	3TTW+10P(BC), Tapping screw
62	833430080	3TTP+8P(BC), Tapping screw
65	27141098	Bracket, holder
68	834430068	3TTS+6B(BC), Tapping screw
81	27180328	Roller spring
85	833420068	2TTP+6B(BC), Tapping screw
87	27141105A	Bracket
88	82112606	2.6P+6F, Pan head screw
U10	10498544-1	NATRM-2844-1, Terminal pc board ass'y
U11	10498545-1	NASW-2845-1, Start switch pc board ass'y
(S841)	25065261	NMS-1212, Microswitch
U12	10498546-1	NASW-2846-1, Open switch pc board ass'y
(S821)	25065260	NMS-1211, Microswitch
U13	10498547-1	NASW-2847-1, Close switch pc board ass'y
(S831)	25065261	NMS-1212, Microswitch

DISASSEMBLING PROCEDURES

1. Tray panel removal

- 1) Remove the tray with pressing the OPEN/CLOSE button.
- 2) Turn the unit over and put it on the soft cloth.
- 3) Remove the two screws from the tray.

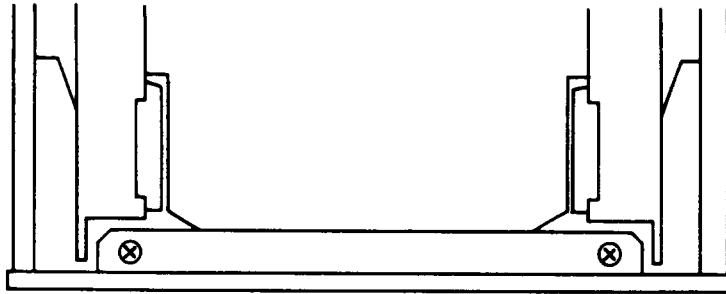

2. Tray removal

- 1) Remove the top cover.
- 2) Open the tray with pressing the OPEN/CLOSE button.
- 3) Release the hook of tray from stopper and pull the tray out.

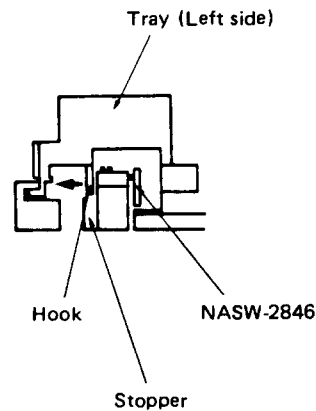

3. Mechanical chassis removal

- 1) Remove the top cover and tray.
- 2) Remove the three screws A from the mechanical chassis.
- 3) Remove the two connectors (P101 & P102) from the main pc board.
- 4) Pull the mechanical chassis out carefully.
- 5) Remove the two connectors (P201 & P202) from the terminal pc board.

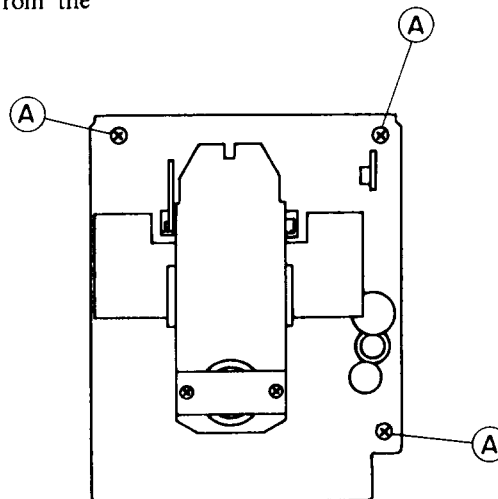

4. Arm P removal

- 1) Remove the top cover.
- 2) Remove a screw B from the bracket, holder.
- 3) Remove the arm P from the stopper.

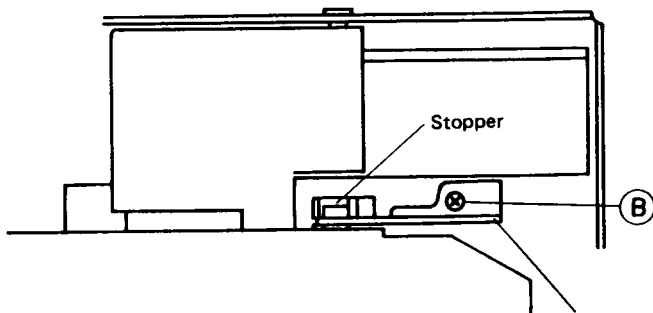

5. Replacing the spindle motor and turntable platter

- 1) Remove the tray and arm P.
- 2) Cut the points C of turntable platter with the pincers and pull it out from the shaft of spindle motor.
- 3) Remove the two screws D from the mechanical chassis.

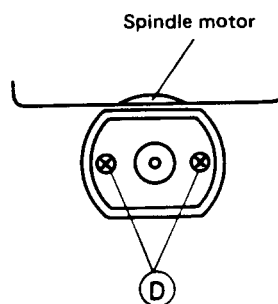
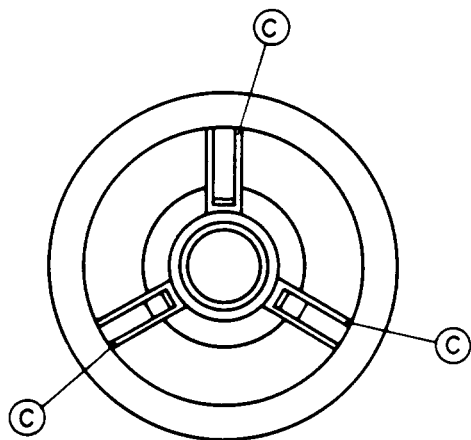

Press the center of turntable platter and insert the turntable platter in the shaft of spindle motor.

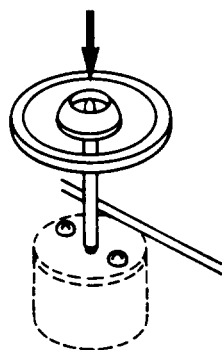

Height of turntable platter.

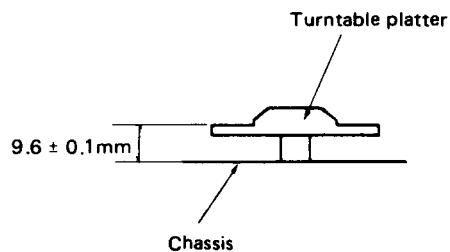

CXA1082AQ (Servo Signal Processor)

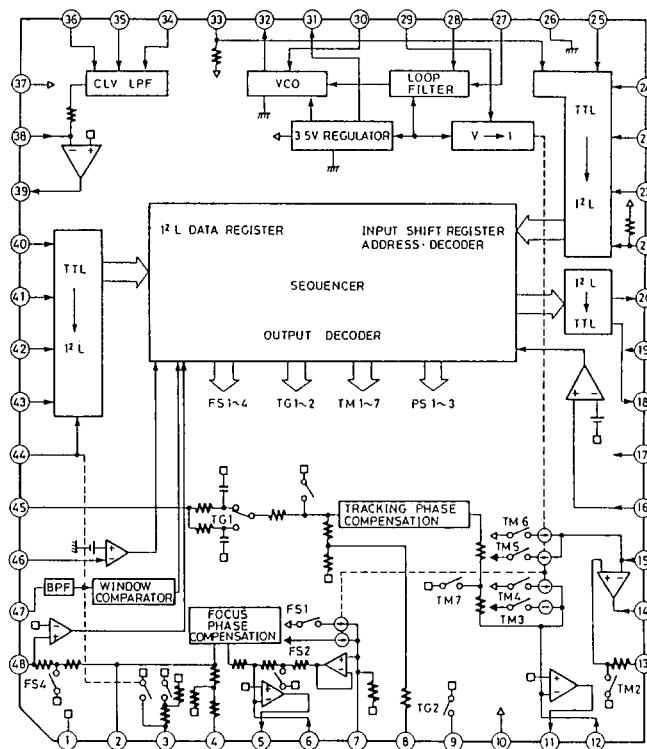

Pin No.	Symbol	Function	Pin No.	Symbol	Function
2	FGD	Insert the capacitor between this terminal and pin 3 when drop the high frequency gain of focus servo	28	PDI	Input terminal of phase comparator output PDO
3	FS3	Switching terminal of high frequency gain of focus servo	21	DIRCT	Input terminals for microcomputer and interface
4	FLB	Time constant switching terminal when raise the low frequency gain of focus servo	22	XRST	
5	FEO	Operation amplifier output terminals for power transistor drive	23	DATA	
11	TAO		24	XTL	
14	SLO		25	CLK	
39	SPDLO		33	LOCK	
6	FE-	Inversion input terminal of focus amplifier	29	ISET	Flow the current to decide the focus search, track jump, and kick height
7	SRCH	Time constant terminal to make the focus search waveform	30	VCOP	VCO free run frequency is proportion to resistor value between pins 30 and 31
8	TGU	Time constant terminal for high frequency gain switching of tracking	32	C864	VCO (8.64MHz) output terminal
9	TG2	Time constant terminal for high frequency gain switching of tracking	34	MDP	Connection terminal to terminal MDP of CXD1135Q
12	TA-	Inversion input terminal of tracking amplifier	35	MON	Connection terminal to terminal MON of CXD1135Q
13	SL+	Non-inversion input terminal of sled amplifier	36	FSW	LPF time constant terminal of CLV servo error signal
15	SL-	Inversion input terminal of sled amplifier	38	SPDL-	Inversion input terminal of spindle drive amplifier
16	SSTOP	Limit switch ON/OFF detector signal terminal for disc innermost position detector	40	WDCK	Input terminals for microcomputer and interface
17	FSET	Terminal of peak of phase compensation of focus tracking and of setting of LPF	41	FOK	
18	SENS	Output terminals for microcomputer and interface	42	MIRR	
20	C.OUT		44	DFCT	
27	BW	Time constant terminal of loop filter	45	TE	Tracking error signal input terminal
			46	TZC	Tracking zero cross comparator input terminal
			47	ATSC	Window comparator input terminal for ATSC detection
			48	FE	Focus error signal input terminal

CXD1135Q (Digital Signal Processor)

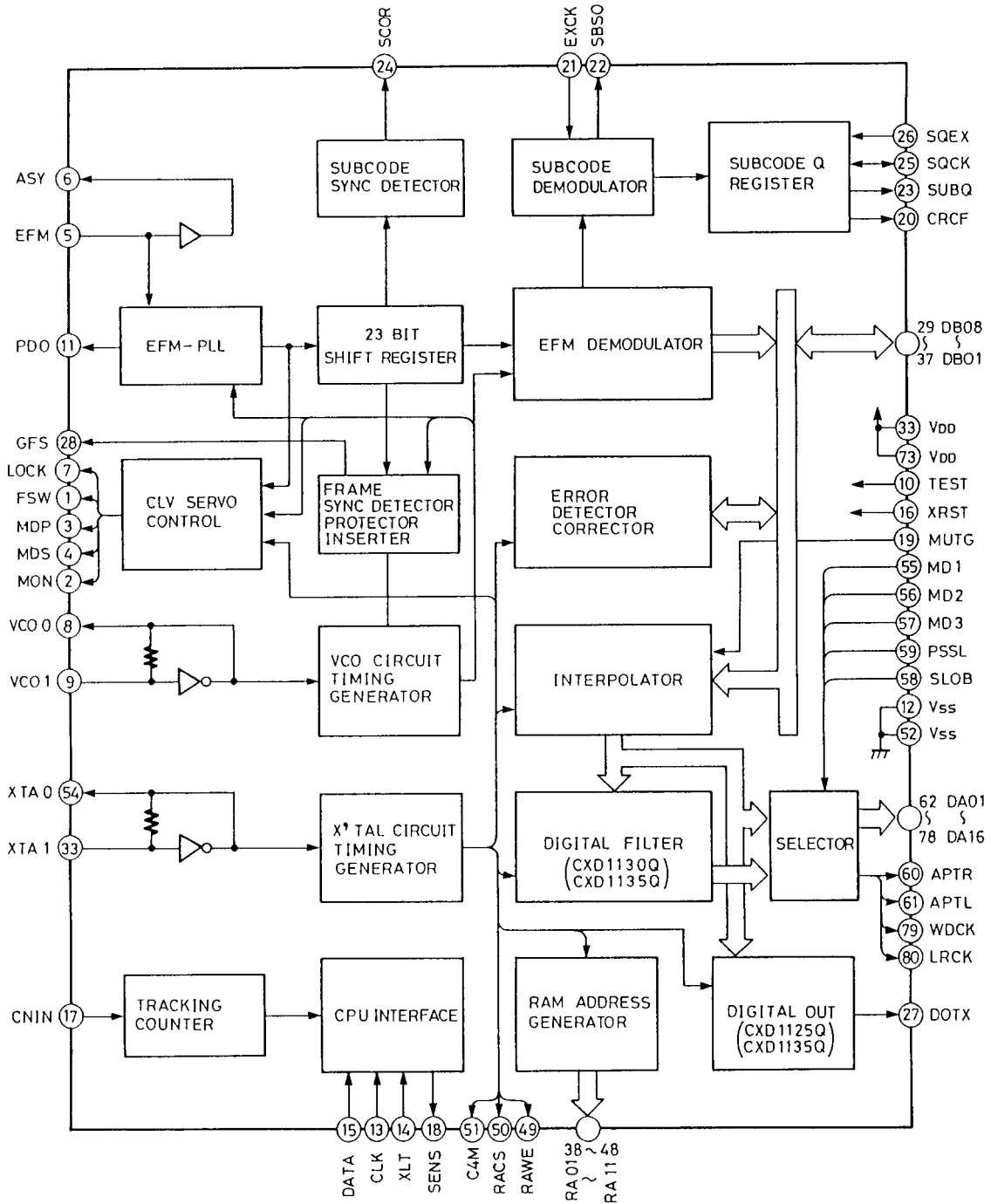

PCM-56P (D/A Converter)

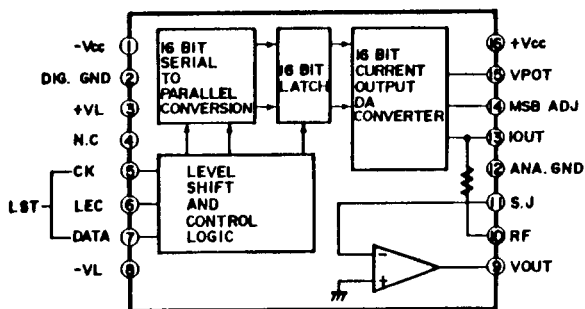

1	-Vcc	Analog power supply (-)	9	VOUT	Output
2	DIG. GND	Digital ground	10	RF	Feedback register
3	+VL	Logic voltage (+)	11	SJ	Operation amplifier input
4	N.C	Not used	12	ANA. GND	Analog ground
5	CK	Clock input	13	IOUT	Current output
6	LEC	Latch enable input	14	MSB ADJ	MSB adjustment terminal
7	DATA	Data input	15	VPOT	Meter terminal
8	-VL	Logic voltage (-)	16	+Vcc	Analog power supply (+)

Pin No.	Symbol	Function	Pin No.	Symbol	Function
1	FSW	Time constant switching output terminal of output filter of spindle motor	49	RAWE	Write enable signal output to external RAM
2	MON	ON/OFF control output terminal of spindle motor	50	RACS	Chip selector signal output to external RAM
			51	C4M	Divider output of crystal. f=4.2336MHz
3	MDP	Drive output terminal of spindle motor. Rough control when mode CLV-S and phase control when mode CLV-P	52	Vss	Ground
			53	XTAI	Input terminal of crystal oscillator
4	MDS	Drive output terminal of spindle motor. Speed control when mode CLV-P	54	XTAO	Output terminal of crystal oscillator
			55	MD1	Mode switching input terminals
5	EFM	EFM signal input terminal from RF amplifier	57	MD3	
6	ASY	Output terminal to control the slice level of EFM signal	58	SLOB	Code switching input of audio data output.
7	LOCK	GFS sampling terminal	59	PSSL	Mode switching input of audio data output. Serial output at low level. Parallel output at high level
8	VCOO	VCO output terminal. 8.6436MHz when lock to EFM signal			
9	VCOI	VCO input terminal	60	APTR	Control output for aperture correction. High level when Rch.
10	TEST	0V	61	APTL	Control output for aperture correction. High level when Lch.
11	PDO	Phase comparator output terminal of EFM signal and VCO/2	62	DA01	DA01 (LSB of parallel sound output) output when PSSL = H. C1F1 output when PSSL = L
12	Vss	Ground	63	DA02	DA02 output when PSSL = H. C1F2 output when PSSL = L.
13	CLK	Serial data transmitter clock input terminal from microcomputer	64	DA03	DA03 output when PSSL = H. C2F1 output when PSSL = L.
14	XLT	Latch input terminal from microcomputer	65	DA04	DA04 output when PSSL = H. C2F2 output when PSSL = L.
15	DATA	Serial data input terminal from microcomputer	66	DA05	DA05 output when PSSL = H. C2FL output when PSSL = L.
16	XRST	System rest input terminal. Reset at low level.	67	DA06	DA06 output when PSSL = H. C2PO output when PSSL = L.
17	CNIN	Tracking pulse input terminal	68	DA07	DA07 output when PSSL = H. RFCK output when PSSL = L.
18	SENS	Inner condition output terminal correspond to address	69	DA08	DA08 output when PSSL = H. WFCK output when PSSL = L.
19	MUTG	Muting input terminal	70	DA09	DA09 output when PSSL = H. PLCK output when PSSL = L.
20	CRCF	CRC check output terminal of subcode Q			
21	EXCK	Clock input terminal for serial output of subcode	71	DA10	DA10 output when PSSL = H. UGFS output when PSSL = L.
22	SBSO	Serial output terminal of subcode	72	DA11	DA11 output when PSSL = H. GTOP output when PSSL = L.
23	SUBQ	Subcode Q output terminal			
24	SCOR	Subcode sink S0 + S1 output terminal	73	V _{DD}	Power supply (5V)
25	SQCK	Clock terminal to read the subcode Q			
26	SQEX	Selector input terminal of SQCK	74	DA12	DA12 output when PSSL = H. RAOV output when PSSL = L.
27	DOTX	Digital output terminal	75	DA13	DA13 output when PSSL = H. C4LR output when PSSL = L.
28	GFS	Indicator output of lock condition of frame sync	76	DA14	DA14 output when PSSL = H. C210 output when PSSL = L.
29	DB08	Data terminals of external RAM			
32	DB05		77	DA15	DA15 output when PSSL = H. C210 output when PSSL = L.
33	V _{DD}	+5V			
34	DB04	Data terminals of external RAM	78	DA16	DA16 (MSB of parallel sound output) output when PSSL = H. DATA output when PSS = L
37	DB01		79	WDCK	Strobe signal output. 176.4kHz when DF is on. 88.2kHz when DF is off.
38	RA01	Address output terminals of external RAM			
48	RA11		80	LRCK	Strobe signal output. 88.2kHz when DF is on. 44.1kHz when DF is off.

16-MT-02GK (Fluorescent Indicator Tube)

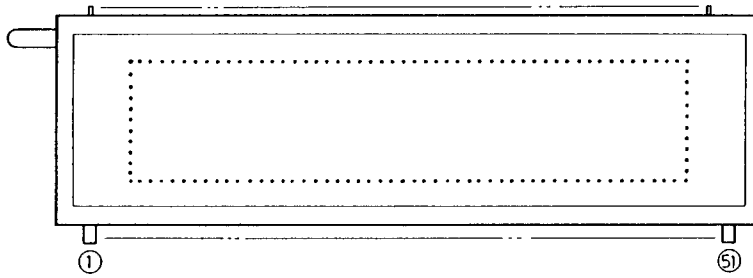

Grid assignment

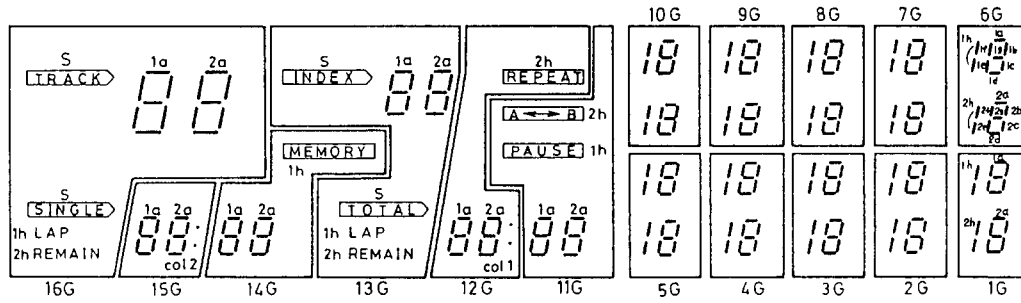

Pin connection

PIN NO.	1	2	3	4	5	6	7	8	9	10	11	12	13	14	15	16	17	18	19	20	21	22	23	24	25	26	
CONNECTION	F	F	N	N	h	a	b	f	g	c	e	d	N	N	G	G	P	N	N	G	N	N	N	N	G	N	P
PIN NO.	27	28	29	30	31	32	33	34	35	36	37	38	39	40	41	42	43	44	45	46	47	48	49	50	51		
CONNECTION	11	10	9	8	7	6	N	5	4	3	2	1	s	1	1	1	1	1	1	1	N	N	F	F	2	2	

STA341M (Transistor Array)

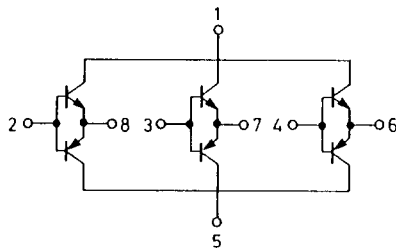

NJM592D8 (Wide Band Amp)

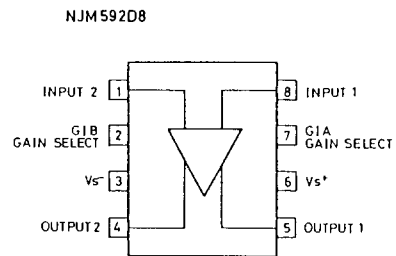

LA6500 (Power OP Amp)

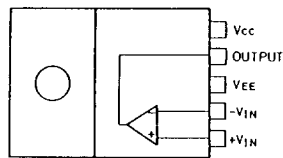

M51944 ASL (System Reset)

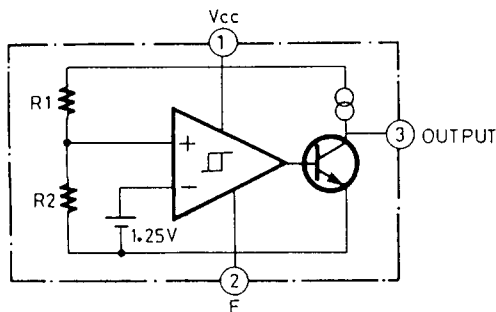

**NJM072BS
NJM4558S (OP Amp)
NJM2068SD**

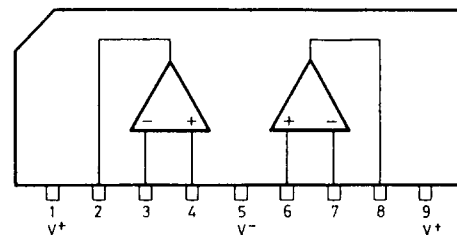

Load the disc on the tray, press OPEN/CLOSE key and close the tray. But, the total time and turn number of times are not indicated on the fluorescent indicator tube.

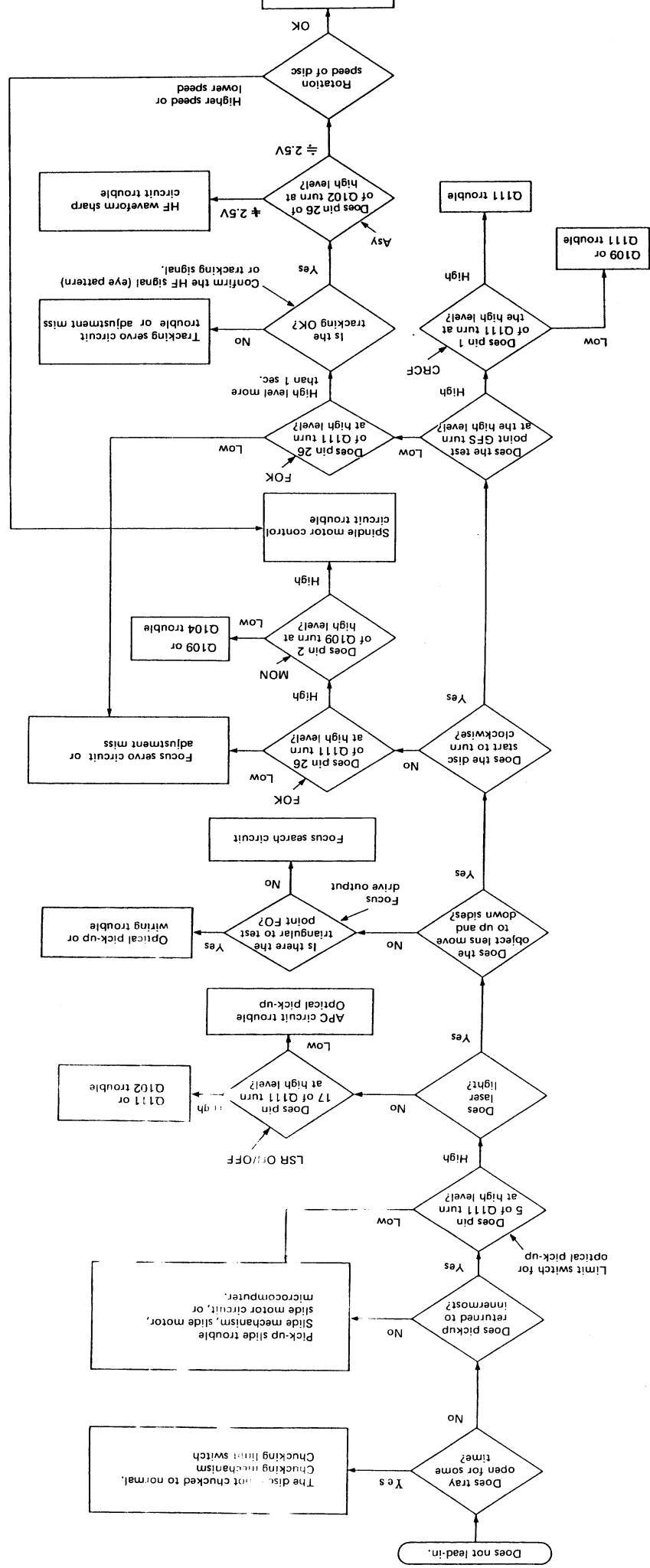

CONNECTION DIAGRAM OF MICROCOMPUTER

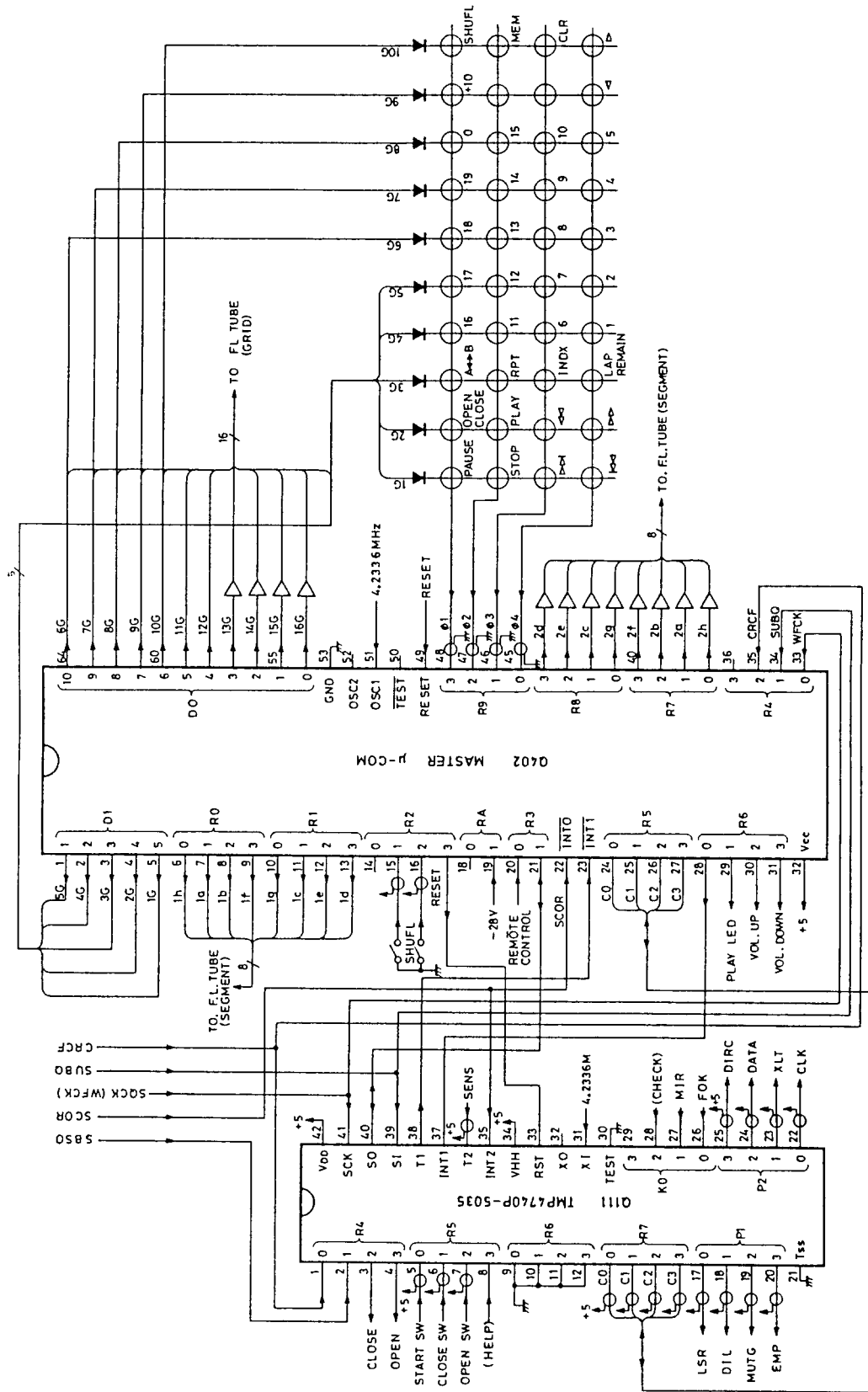

CIRCUIT DESCRIPTIONS

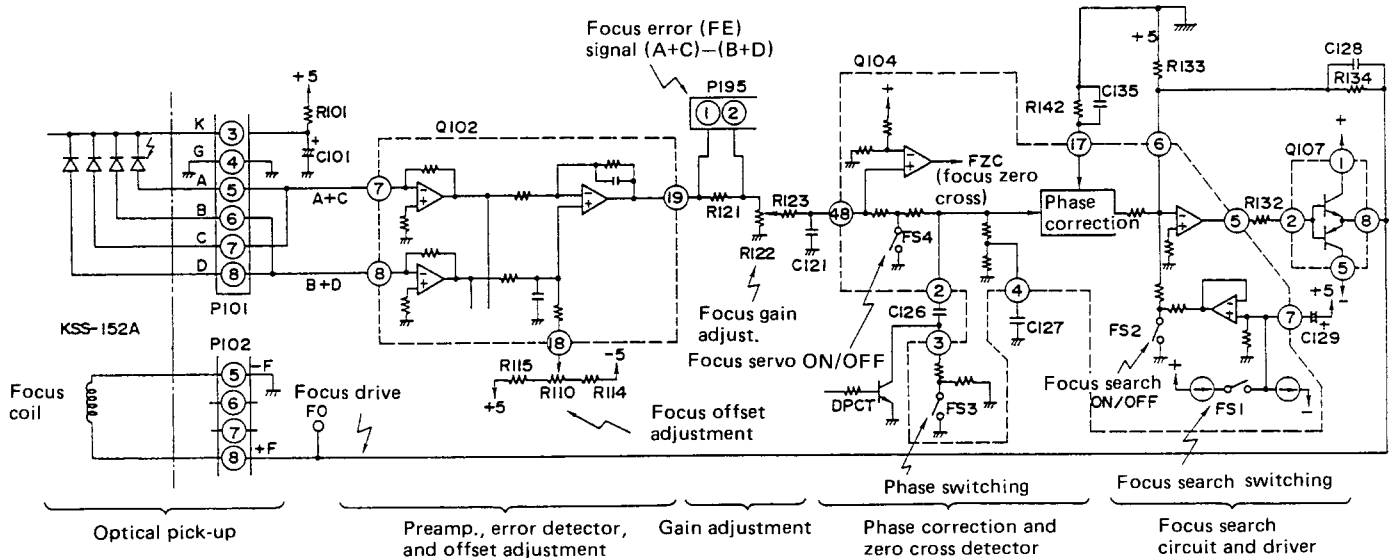

Fig. 1 Focus servo circuit

1. Focus servo circuit

From the optical pickup objective lens, the emitted laser beam is focused on the disc reflecting surface, and this circuit controls the movement of the lens up and down.

1-1. Error detecting circuit

The error is detected by means of the astigmatic aberration method and obtains its focus error signal from the optical pickup output signal $(A+C)-(B+D)$.

The individual signals $(A+B)$ and $(C+D)$ input to pins 7 and 8 of Q102 are subtracted by means of the IC internal op amp, and from pin 19, the F.E. signal is output. Also, in order to eliminate the focus error, offset adjustment is carried out by the semi-fixed resistor R110 of pin 18 of Q102.

1-2. Phase correction and driver circuit

By means of the semi-fixed resistor R122, the gain adjusted F.E. signal passes by way of the phase correction circuit from pin 48 of Q104, and from pin 5 of Q104 to the driver Q107, and is feedback to the coil used for driving the optical pickup KSS-152A objective lens. In addition, there are the FS4 servo ON/OFF switch and FS3 phase characteristic selector switch.

1-3. Focus zero cross circuit and focus search circuit

In order to have mandatory drive of the objective lens in the capture range of only $10\mu\text{m}$ at the focus point it is necessary to turn off the above mentioned FS4 and close the servo loop. The timing diagram for that operation is shown in Fig. 2.

The triangular wave generated by means of the focus search circuit internal to Q104 shifts the objective lens up/down direction, and at the correct focus point, the fall of F.E. signal is detected by the focus zero cross (FZC) circuit to close the servo loop. At this time, it is necessary that the focus OK (FOK) signal be in the high level. In Fig. 2, the dotted line is the waveform of the focus capture failure.

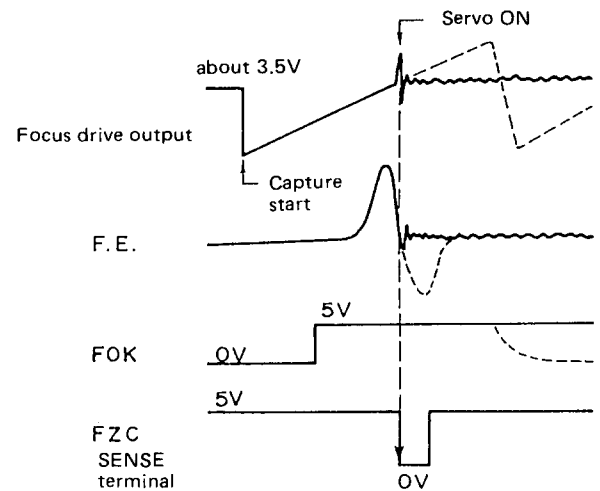

Fig. 2 Capture operation of focus

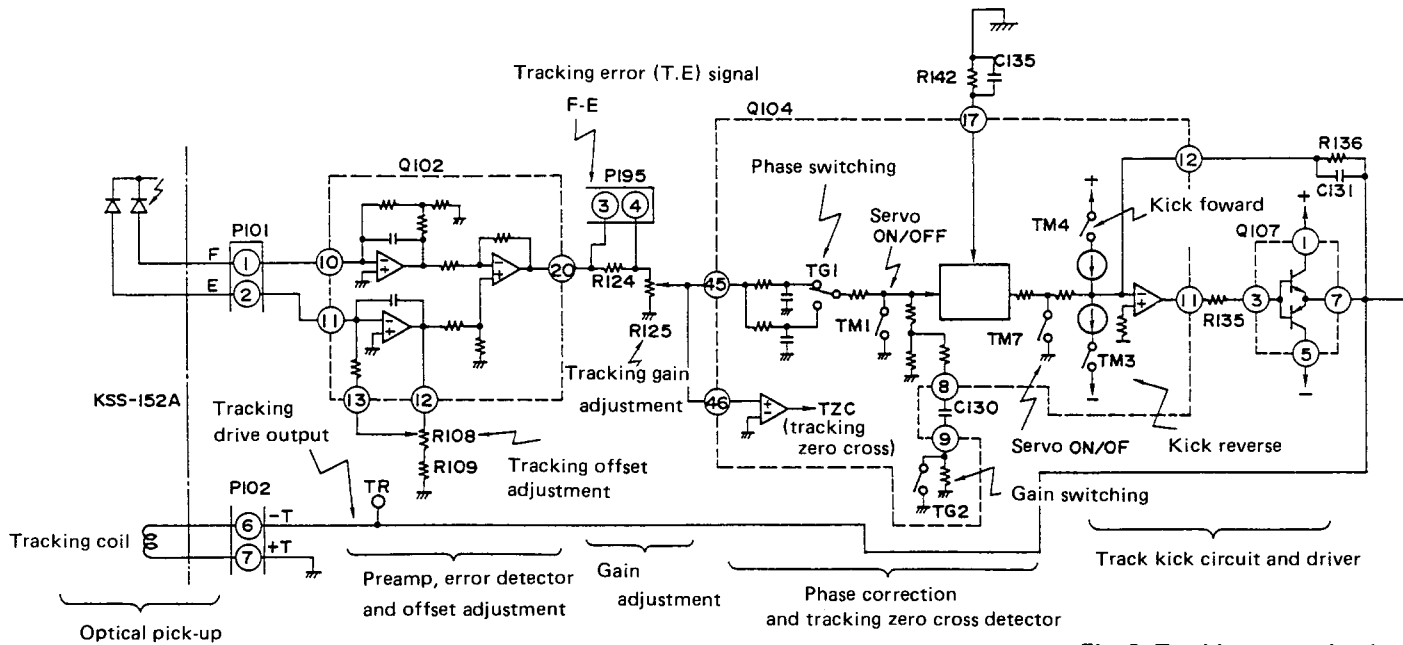

Fig. 3 Tracking servo circuit

2. Tracking servo circuit

On the disc at a pitch of $1.6\mu\text{m}$, the laser beam accurately traces the center of the pits cut into the disc, and this is the control circuit that shifts the objective lens in the radial direction.

2-1. Error detection circuit

The F-E is obtained from the tracking error (T.E.) signal by means of a 3 beam method. The F.E. signal input to pins 10 and 11 of Q102 is subtracted internally, and is output as the T.E. signal from pin 20. R108 is the semi-fixed resistor control for tracking offset.

2-2. Phase correction and driver circuit

The T.E. signal adjusted for gain by means of the semi-fixed resistor R125 passes through the phase correction circuit from pin 45 of Q104, and from pin 11 by way of driver Q107 objective lens. TM1 and TM7 are used as the tracking servo ON/OFF switches, and TG1 and TG2 respectively are used as the phase selector and gain selector switches.

2-3. Tracking zero cross and track kick circuit

At the time the head comes out and when there is manual fast forward, in the event that it is necessary to skip over the track being traced, the T.E. signal receives a kick pulse, and by means of this, shifting of the objective lens can be achieved.

TM3 and TM4 respectively are the switches for providing the forward and reverse direction kick pulses. Also, the tracking zero cross (TZC) circuit counts the number of tracks skipped over and produces the signal in order to determine the timing of the servo ON/OFF.

The ON/OFF command for these switches is output from the microcomputer.

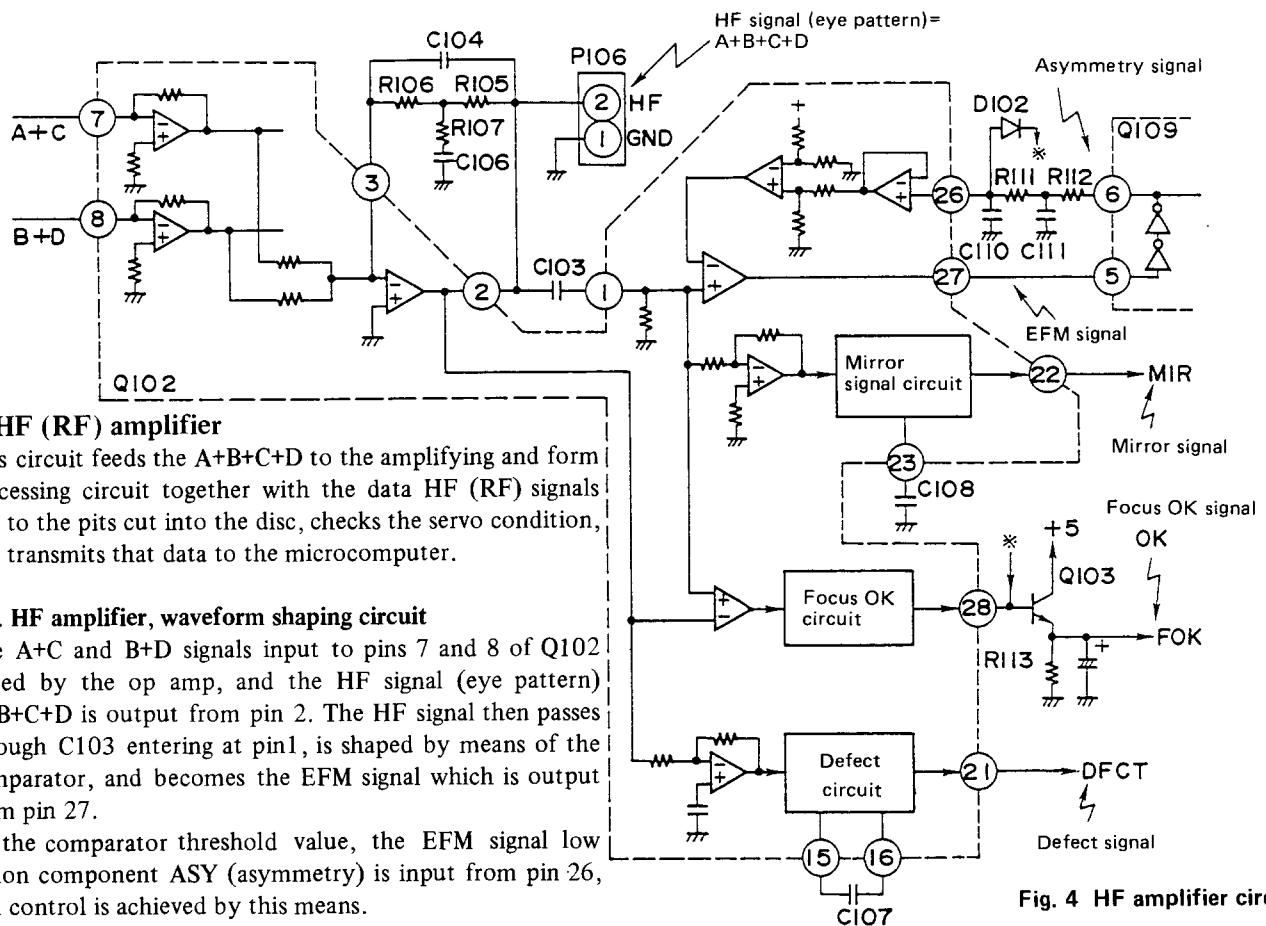

Fig. 4 HF amplifier circuit

3. HF (RF) amplifier

This circuit feeds the $A+B+C+D$ to the amplifying and form processing circuit together with the data HF (RF) signals due to the pits cut into the disc, checks the servo condition, and transmits that data to the microcomputer.

3-1. HF amplifier, waveform shaping circuit

The $A+C$ and $B+D$ signals input to pins 7 and 8 of Q102 added by the op amp, and the HF signal (eye pattern) $A+B+C+D$ is output from pin 2. The HF signal then passes through C103 entering at pin 1, is shaped by means of the comparator, and becomes the EFM signal which is output from pin 27.

In the comparator threshold value, the EFM signal low region component ASY (asymmetry) is input from pin 26, and control is achieved by this means.

3-2. MIR circuit, FOK circuit, and DFCT circuit

After the HF signal is processed the detection, shaping, etc, respectively the MIR, FOK, and DFCT signals are output from pins 22, 28, and 21.

3-2-1. MIR (mirror) signal

When the head is extended, at the time the signal becomes high at the disc track and between tracks, the number of tracks is counted, and this is used for determining the timing for the ON/OFF of the servo.

3-2-2. FOK (focus OK) signal

This signal goes high at the time the focus servo is required. (Refer to 1-3)

3-2-3. DFCT (defect) signal

If there is a defect (scratch, dirt, etc.) in the disc, this signal goes high, the servo and gain are controlled, and the circuit prevents a sound outburst.

4. APC circuit

By means of feedback from the monitor, this circuit controls the light output due to a bad condition resulting from the temperature characteristic of the laser diode.

For the pin 29 LDON (laser diode ON) signal, when the APC ON/OFF control signal is LOW, the laser is emitted.

5. CLV servo circuit

In the compact disc there is a CLV system (constant linear velocity), and at the replay position, because the disc rotary speed varies, the clock is taken out of the HF signal, and

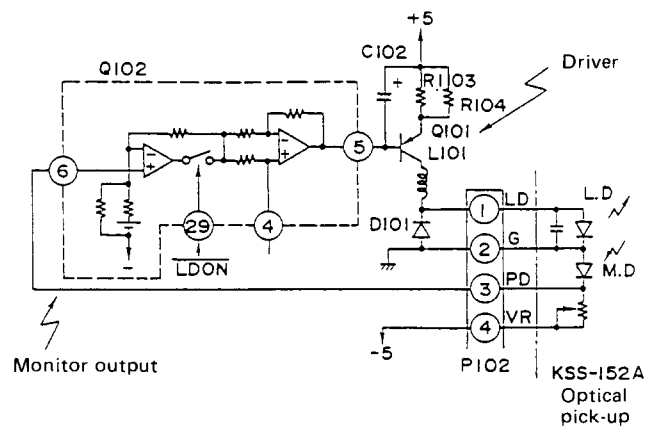

Fig. 5 APC circuit

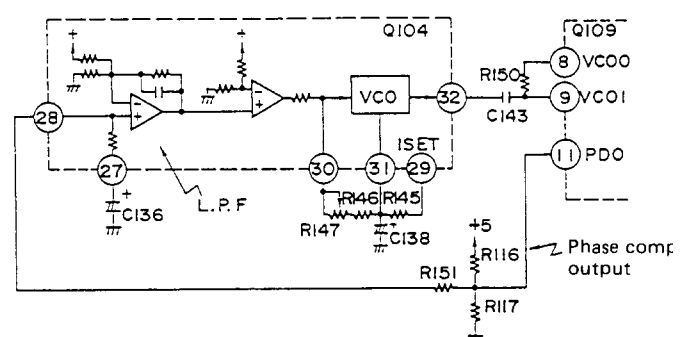

Fig. 6 PLL circuit

the PLL circuit and its clock must be synchronized to control the spindle motor.

5-1. PLL circuit

As shown in Fig. 6, for the phase comparator, in Q109 the LPF and VCO are each built into Q104. The semi-fixed resistor R147 is the control for adjusting the 8.6436 MHz free run frequency (WFCK = 7.35 KHz).

5-2. Spindle motor control circuit

The output of the phase comparator (MDP) and frequency comparator (MDS) from pins 3 and 4 of Q109 is fed to pins 34 and 36 of Q104. Also, the spindle motor ON/OFF signal (MON) from pin 2 of Q109, and the phase selector signal (FSW) from pin 1, are output and fed to pin 36 of Q104. After these signals are processed in Q104, they are passed from pin 39 through the driver Q108, and are supplied to the spindle motor.

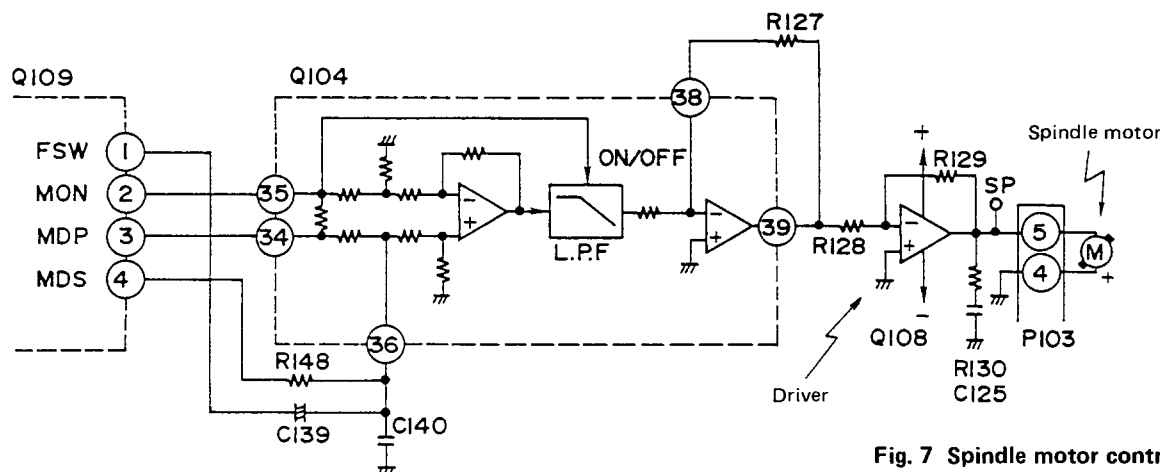

Fig. 7 Spindle motor control circuit

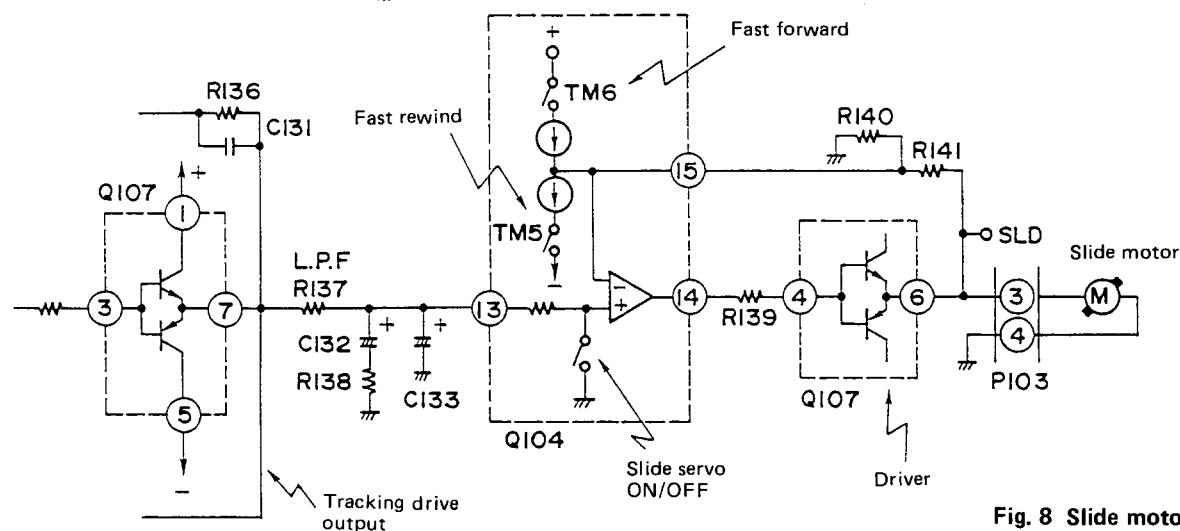

Fig. 8 Slide motor circuit

6. Slide motor circuit

This circuit controls the slide motor which is used for moving the optical pickup from inside the disc to the outside. In the normal playback time, the low region component of the tracking driver output is amplified and fed to the motor, but when the head is extended, switches TM5 and TM6 internal to Q104 control the ON/OFF.

7. Microcomputer peripheral circuit

Controlling is done with 2 microcomputer, and on the indicator printed circuit board, the master microcomputer is located. The primary operations are as shown in the following:

Master microcomputer Q401 (64 pin, 8K)

Key input processing 10 digit x 4 input

Display control 10 digit x 16 segment output

Remote control input

processing Serial input

Submicrocomputer

control 4 bit parallel output

Subcode return (only at

lead in time) Serial input + clock

Submicrocomputer Q111 (42 pin, 4K)

Servo system controller . . . Serial output + clock

Mechanism controller. Starting output, input

Muting/emphasis

control Starting output

Subcode return Serial input + clock, parallel output

ADJUSTMENT PROCEDURES

Instruments required

Dual trace oscilloscope, Frequency counter, CR oscillator, Test disc (SONY YEDS-18), AC voltmeter, Sockets P107 & P105 (Part No.25050089) P106 (Part No. 25050138)

1. VCO frequency adjustment

Connect the frequency counter to terminal P107.

Turn the power switch to ON.(No load the disc).

Adjust R147 until the frequency counter reading becomes 7.35kHz.

After adjustment, disconnect the frequency counter.

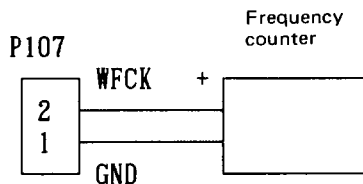

2. Focus offset adjustment

Load the test disc (YEDS-18) on the tray and play back the track 2.

Connect the oscilloscope to terminal P105.

Adjust R110 until a clear trace of waveform pattern as shown photo 1 appear on the oscilloscope.

(When the amount of jitter is broad, set R110 to mechanical center)

After adjustment, disconnect the oscilloscope.

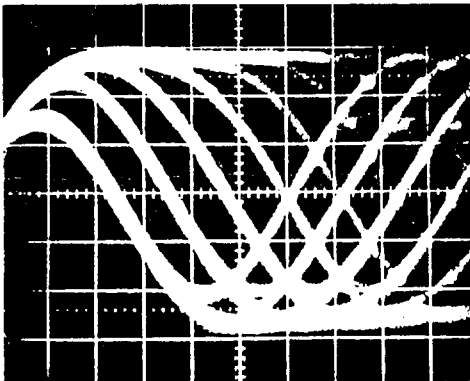
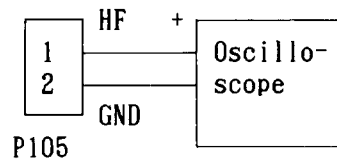

Photo 1



Oscilloscope range
Vertical: 0.2V/div
Horizontal: 0.2μS/div

3. Tracking offset adjustment

Play back the track 2 of test disc.

Turn R125 to minimum position(counter-clockwise).

Connect the oscilloscope between pin 3 (TR) of P106 and pin 2 (GND) of P105.

Adjust R108 until the center of tracking error signal on the oscilloscope becomes GND level.

Turn R125 to mechanical center.

After adjustment, disconnect the oscilloscope.

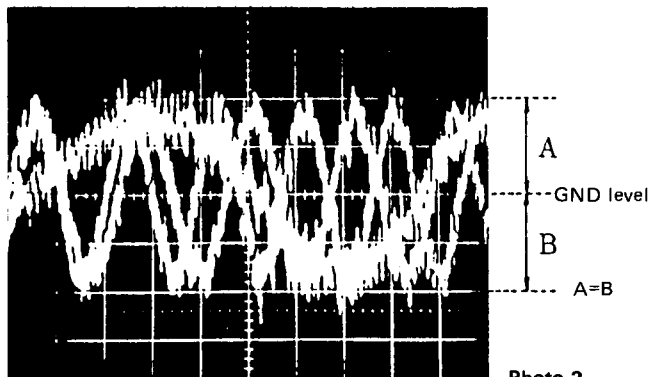
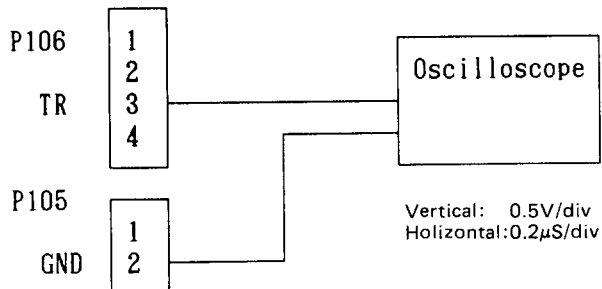

Photo 2



Vertical: 0.5V/div
Horizontal: 0.2μS/div

4. Focus gain adjustment

Set the output of CR oscillator to 800Hz, 1~1.5Vp-p.

Play back the track 2 of test disc.

Connect the oscilloscope and the CR oscillator as shown below.

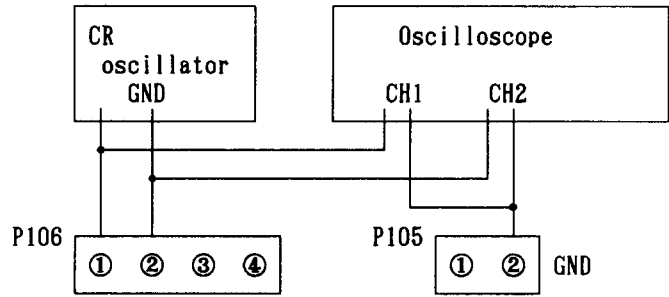
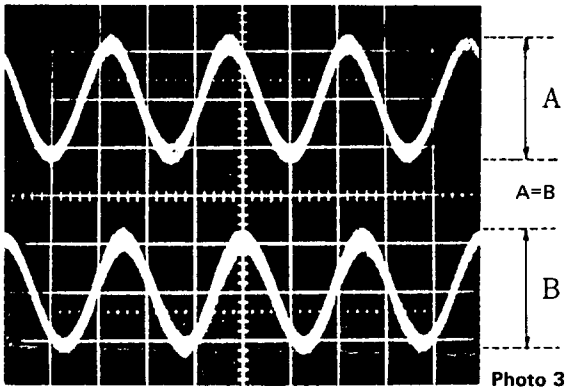

Vertical: 0.5V/div
Horizontal: 0.5mS/div

Adjust R122 until 800Hz components of CH1 and CH2 on oscilloscope become same level.

After adjustment, disconnect the CR oscillator and the oscilloscope.

5. Tracking gain adjustment

Set the output of CR oscillator to 1.2kHz, 1~1.5Vp-p.

Play back the track 2 of test disc.

Connect the oscilloscope and the CR oscillator as shown below.

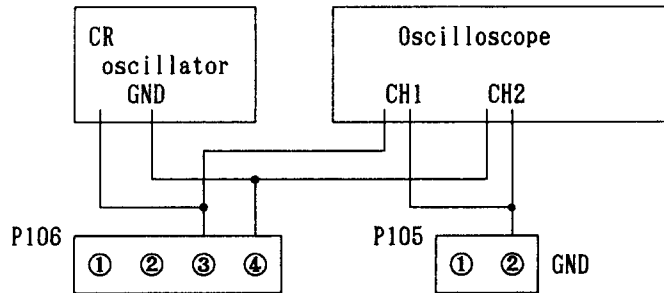
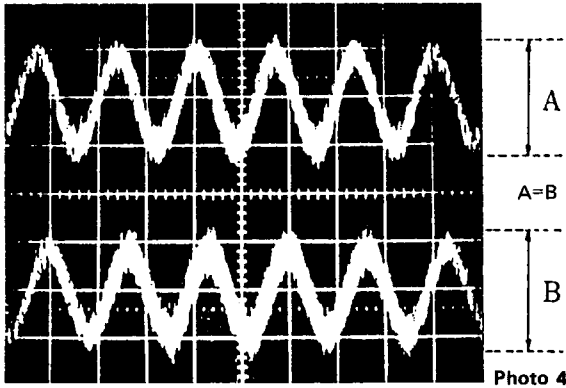

Vertical : 0.5V/div
Horizontal: 0.5mS/div

Adjust R125 until 1.2kHz components of CH1 and CH2 on oscilloscope becomes same level.

After adjustment, disconnect the CR oscillator and the oscilloscope.

6. Bet clock adjustment (BCLK adjustment)

Connect the oscilloscope to the test point BCLK.

Adjust R201 until the duty ratio of clock waveform becomes 1:1.

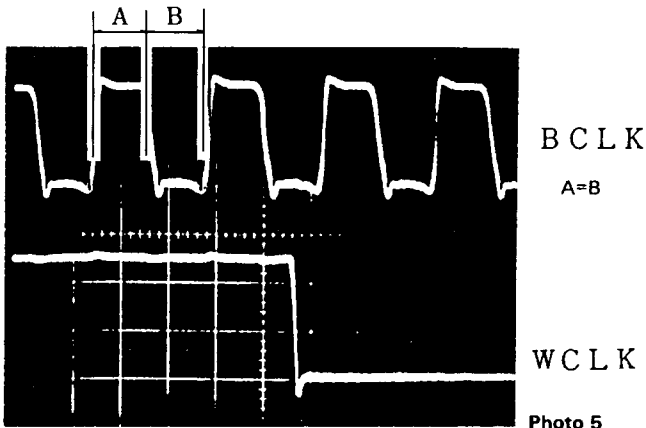

Vertical: 2V/div
Horizontal: 0.1μS/div

7. Data waveform adjustment

Play back the track 2 of test disc.

Connect the channel 1 of oscilloscope to the test point DATA.

Connect the channel 2 of oscilloscope to the test point BCLK (synchronization signal).

Adjust R204 until the cross point of data waveform becomes 3V from below section.

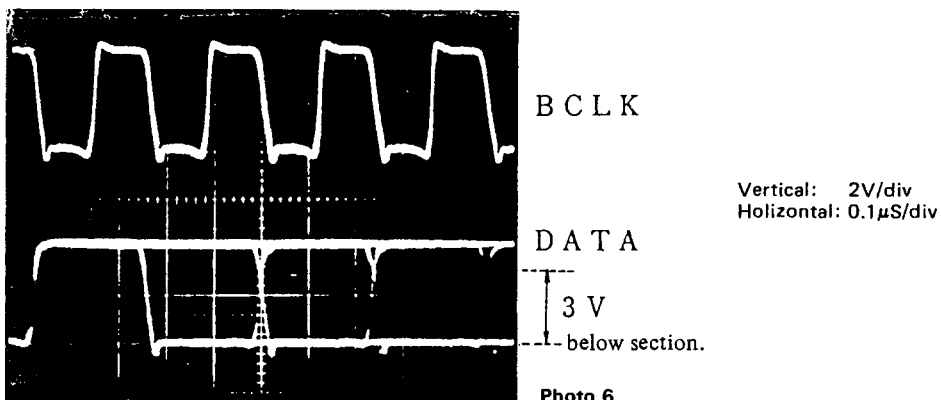

8. Zero cross distortion waveform adjustment

Connect the AC voltmeter to the audio output (L ch. or R ch.).

Adjust R310 until the playback level of track 17 becomes -60dB of playback level of track 2.

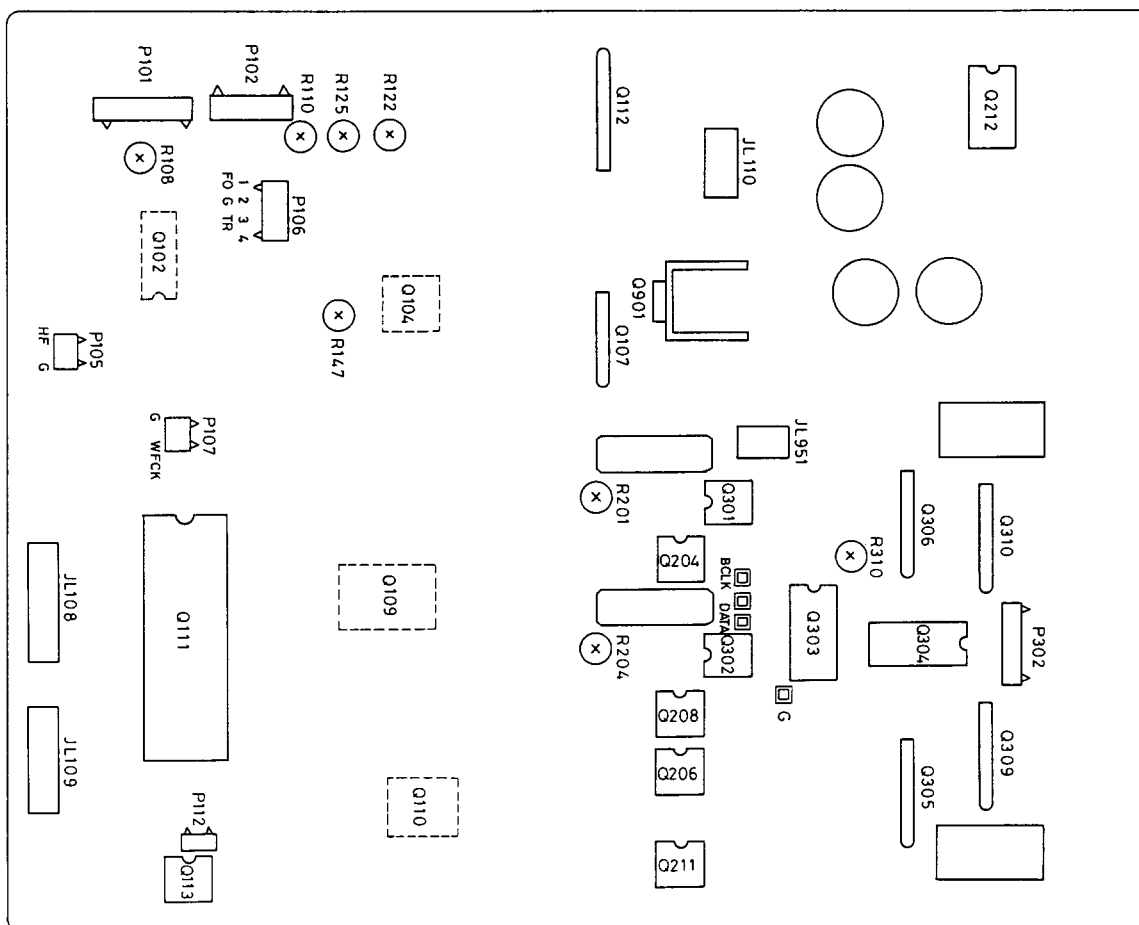

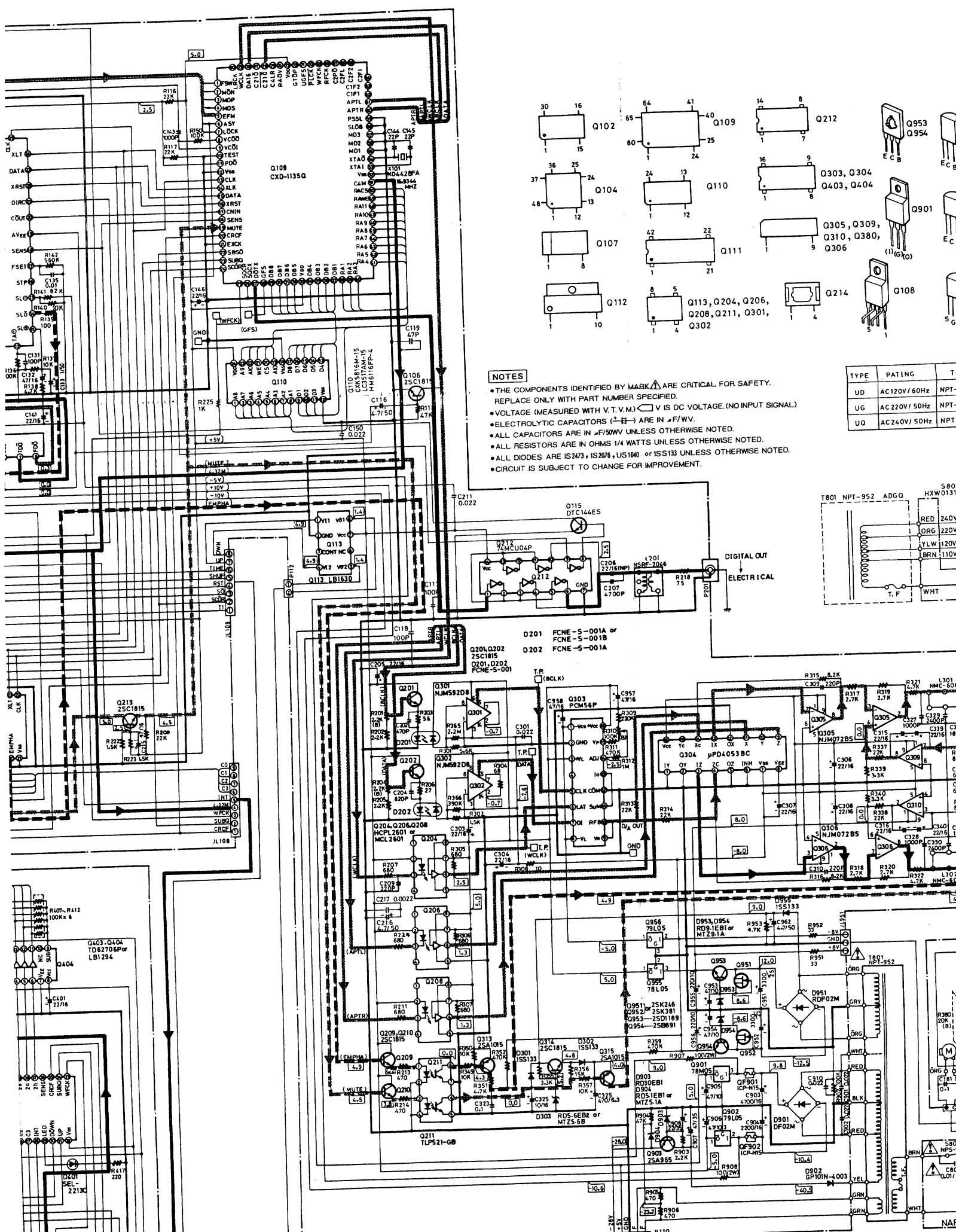

NOTES

- THE COMPONENTS IDENTIFIED BY MARK Δ ARE CRITICAL FOR SAFETY. REPLACE ONLY WITH PART NUMBER SPECIFIED.
- VOLTAGE (MEASURED WITH V. T. M.) \square V IS DC VOLTAGE. (NO INPUT SIGNAL)
- ELECTROLYTIC CAPACITORS ARE IN μ F/50V UNLESS OTHERWISE NOTED.
- ALL CAPACITORS ARE IN μ F/50V UNLESS OTHERWISE NOTED.
- ALL RESISTORS ARE IN OHMS 1/4 WATTS UNLESS OTHERWISE NOTED.
- ALL DIODES ARE IS2473, IS2076, US1040 OR ISS133 UNLESS OTHERWISE NOTED.
- CIRCUIT IS SUBJECT TO CHANGE FOR IMPROVEMENT.

TYPE	PATING	T F
UD	AC120V/60HZ	NPT-
UG	AC220V/50HZ	NPT-
UQ	AC240V/50HZ	NPT-

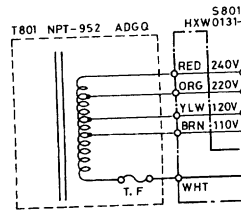

PRINTED CIRCUIT BOARD – PARTS LIST

MAIN CIRCUIT PC BOARD (NAAR-2929-2)

CIRCUIT NO.	PART NO.	DESCRIPTION			
ICs					
Q102	22240029	CXA1081M	D904	2239451 or	RD5.1EB1 or
Q104	22240030	CXA1082AQ		2243141	MTZ5.1A
Q107	22240036	STA341M	D951	22380013	RDF02M
Q108	22240033	LA6500	D953, D954	2239571 or	RD9.1EB1 or
Q109	22240031	CXD1135Q		2243201	MTZ9.1A
Q110	222990, 222882 or 22240032	CXK5816M-15, HM6116FP-4 or LC3517AM-15	D955	223163	1SS133
Q111	222948	TMP4740P-5035	X101	X'tal 3010112	KD6586FFB
Q112	22240034	LA6510		Coils	
Q113	222963	LB1630	L101	231023	NCH-1062
Q204, Q206	226027 or	HCPL2601 or	L201	232136	NSRF-2046
Q208	226026	MCL2601	L301, L302	232134	NMC-6062
Q211	2412002	TLP521-2GB	L303, L304	231066	NCH-1118
Q212	222755	74HCU04P		Capacitors	
Q301, Q302	22240035	NJM592D8	C101	354742209	22 μ F, 16V, Elect.
Q303	222988	PCM56P	C102	354721019	100 μ F, 6.3V, Elect.
Q304	222717	μ PD4053BC	C112	354780479	4.7 μ F, 50V, Elect.
Q305, Q306	22240010	NJM072BS	C113, C114	354742209	22 μ F, 16V, Elect.
Q309, Q310	22240020	NJM2068SD	C116, C129	354780479	4.7 μ F, 50V, Elect.
Q901	222780052	78M05	C132	354744709	47 μ F, 16V, Elect.
Q902, Q956	222790053	79L05	C133	354780109	1 μ F, 50V, Elect.
Q955	222780053	78L05	C136	354780479	4.7 μ F, 50V, Elect.
	Transistors		C138	354744709	47 μ F, 16V, Elect.
Q101	2211643 or 2211644	2SA965(O) or 2SA965(Y)	C141, C142	354742209	22 μ F, 16V, Elect.
Q103, Q105	2211254 or 2211255	2SC1815(Y) or 2SC1815(GR)	C146, C205	354742209	22 μ F, 16V, Elect.
Q106	2211255	2SC1815(GR)	C152, C206	352942206	22 μ F, 16V, Non-polar elect.
Q114	2212600	DTA124ES	C215	354744709	47 μ F, 16V, Elect.
Q115	221282	DTC144ES	C216	354780479	4.7 μ F, 50V, Elect.
Q201, Q202	2211254 or	2SC1815(Y) or	C218	354741009	10 μ F, 16V, Elect.
Q209, Q210	2211255	2SC1815(GR)	C303, C304	354742209	22 μ F, 16V, Elect.
Q213	2211254 or 2211255	2SC1815(Y) or 2SC1815(GR)	C306-C308	354742209	22 μ F, 16V, Elect.
Q307, Q308	2212375	2SK30ATM(GR)	C309, C310	372522214	220pF \pm 5%, 50V, Styrole
Q311, Q312	2211705 or 2211706	2SD655(E) or 2SD655(F)	C315, C316	391242209	22 μ F, 16V, Elect.
Q313, Q315	2211454 or 2211455	2SA1015(Y) or 2SA1015(GR)	C317-C320	372522214	220pF \pm 5%, 50V, Styrole
Q314	2211254 or 2211255	2SC1815(Y) or 2SC1815(GR)	C324	354741009	10 μ F, 16V, Elect.
Q903	2211643 or 2211644	2SA965(O) or 2SA965(Y)	C325	354724719	470 μ F, 6.3V, Elect.
Q951, Q952	2212304 or 2211945	2SK381(D) or 2SK246(GR)	C339, C340	391242209	22 μ F, 16V, Elect.
Q953	2201594 or 2201595	2SD1189(Q) or 2SD1189(R)	C903	354744729	4700 μ F, 16V, Elect.
Q954	2201604 or 2201605	2SB891(Q) or 2SB891(R)	C904	354742229	2200 μ F, 16V, Elect.
	Photo couplers		C905, C906	354744709	47 μ F, 16V, Elect.
D201	24120005 or 24120006	FCNE-S-001A or FCNE-S-001B	C907	354784709	47 μ F, 50V, Elect.
D202	24120005	FCNE-S-001A	C908	354762209	22 μ F, 35V, Elect.
	Diodes		C951, C952	352753329	3300 μ F, 25V, Elect.
D101, D102	223163	1SS133	C953, C954	354744709	47 μ F, 16V, Elect.
D301, D302	223163	1SS133	C955, C956	354742219	220 μ F, 16V, Elect.
D303	2239472 or 2243152	RD5.6EB2 or MTZ5.6B	C957, C958	354744709	47 μ F, 16V, Elect.
D901	223892	DF02M	C962	354780479	4.7 μ F, 50V, Elect.
D902	223880	GPI01N4003		Resistors	
D903	2239811	RD30EB1	R108	5210066	N06HR22KBD, Semi-fixed
			R110, R147	5210060	N06HR2.2KBD, Semi-fixed
			R122, R125	5210066	N06HR22KBD, Semi-fixed
			R165	49121472408	4.7kohmX8, 1/8W, Network
			R166	49121102404	1kohmX4, 1/8W, Network
			R201, R204	5210009	N06HR2.2KBDM, Semi-fixed
			R310	5210070	N06HR100KBD, Semi-fixed
			R907, R908	442521004	10ohm, 1/2W, Metal oxide film
				Plugs	
			P101	25055153	NPLG-9P137
			P102	25055152	NPLG-8P136
			P105, P107	25055038	NPLG-2P29

P106	25055045	NPLG-4P33
P112	25055132	NPLG-2P116
P302	25055136	NPLG-6P120

Sockets

P103	2000444	NSAS-5P403
P104	2000653	NSAS-4P609
P108	25050273	NSCT-9P101
P109	25050272	NSCT-8P100
P110	25050269	NSCT-5P97
P111	25050268	NSCT-4P96
P951	25050267	NSCT-3P95

Terminals

P201	25045220	NPJ-1PDOR97
P301	25045201	NPJ-4PDBL82

Fuses

F901, F902	252112	△ ICP-N15-0.6A
------------	--------	----------------

Radiator

27160029	RAD-07
----------	--------

Screw

82143006	3P+6FN(BC), Pan head
----------	----------------------

Cushion

28140772

DISPLAY PC BOARD (NADIS-2930-2)

CIRCUIT NO.	PART NO.	DESCRIPTION
Fluorescent tube		
Q401	212038	16-MT-02GK
ICs		
Q402	22240045	HD614088S-B15
Q403, Q404	22240037	TD62706P
Q405	22240038	M51944ASL
L.E.D		
D401	225141	SEL2213C
Diodes		
D402-D404	223163	1SS133
Capacitors		
C401, C403	354742209	22 μ F, 16V, Elect.
C402	354762209	22 μ F, 35V, Elect.
C404	354780479	4.7 μ F, 50V, Elect.
Resistors		
R401-R406	49121104406	100kohmX6, 1/8W, Network
R407-R412	49121104406	100kohmX6, 1/8W, Network
R413-R416	49121102404	1kohmX4, 1/8W, Network
Switches		
S401-S412	25035554	NPS-111-S516
Holders		
	27190516A	
	27190517A	L.E.D
Screws		
	833430080	3TTP+8P(BC), Tapping screw

OPERATION SWITCH PC BOARD (NASW-2931-2)

CIRCUIT NO.	PART NO.	DESCRIPTION
Opto. module		
U451	241068	BX-1407
Diodes		
D451-D457	223163	1SS133
Capacitor		
C451	354742209	22 μ F, 16V, Elect.

Switches

S451-S476	25035548	NPS-111-S510
-----------	----------	--------------

TIMER SWITCH PC BOARD (NASW-2932-2)

CIRCUIT NO.	PART NO.	DESCRIPTION
D501, D502	225142	SEL2913K, L.E.D
S501	25065224	NSS-2398, Slide switch
	27190515B	Holder, L.E.D

OUTPUT VOLUME PC BOARD (NAAF-2933-2)

CIRCUIT NO.	PART NO.	DESCRIPTION
Q380	222887	NJM4556S, IC
C386, C387	354744709	47 μ F, 16V, Elect. Capacitors
R380	5148116	N16RGL20KA20, Variable resistor
SC181	2000654	NSAS-2P610, Socket
SC381	2000675	NSAS-6P631, Socket

HEADPHONE TERMINAL PC BOARD (NAHP-2934-2)

CIRCUIT NO.	PART NO.	DESCRIPTION
P391	25045139	HLJ0541-01-010, Terminal

POWER SWITCH PC BOARD(NAPS-2936-2)

CIRCUIT NO.	PART NO.	DESCRIPTION
S801	25035398	△ NPS-111-S362P, Power switch
C801	3500065A	△ 0.01 μ F, AC125V/400V, Capacitor IS
	27300601	△ Cover for C801

NOTE: THE COMPONENTS IDENTIFIED BY MARK △ ARE CRITICAL FOR RISK OF FIRE AND ELECTRIC SHOCK. REPLACE ONLY WITH PART NUMBER SPECIFIED.